



DS2 Series Servo Driver

User Manual

**DS2 Series Servo Driver
User Manual**

Safety Precautions

Content

Preface

Checking Product and Part Names

Installation

Wiring

Parameter Settings and Functions

Use Digital Panel

Ratings and Characteristics

Alarm Information

Safety Precautions

Be sure to review this section carefully before use this product. In precondition of security, wire the product correctly.

The following defines the symbols used in this manual to indicate varying degrees of safety precautions and to identify the corresponding level of hazard inherent to each. Failure to follow precautions provided in this manual can result in serious, possibly even fatal, injury, and/or damage to the persons, products, or related equipment and systems.



CAUTION

Indicates a potentially hazardous situation, which, if not heeded, could result in death or serious injury



WARNING

Indicates a potentially hazardous situation, which, if not avoided, may result in minor or moderate injury.

● Checking Products upon Delivery



CAUTION

1. DO NOT install any driver which is damaged, lack of accessories or not the same with the model ordered.
Doing so may result in electric shock.

● Installation



WARNING

1. Cut off external power supply before installation.
Not doing so may result in electric shock.



CAUTION

1. Always use the servomotor and servo amplifier in one of the specified combinations.
Never use the products in an environment subject to water, corrosive gases, inflammable gases, or combustibles.
Doing so may result in electric shock, fire or malfunction.
2. DO NOT touch any metallic part.
Doing so may result in malfunction.

● Wiring



WARNING

1. Cut off external power supply before wiring.
Not doing so may result in electric shock.
2. Connect AC power supply to the corresponding terminals.
Faulty wiring may result in fire.



CAUTION

1. Do not connect a three-phase power supply to the U, V, or W output terminals.
Doing so may result in injury or fire.
2. Use 2mm² wire to grounding the ground terminals.
Not doing so may result in electric shock.
3. Securely fasten the power supply terminal screws and motor output terminal screws.
Not doing so may result in fire.

● Operation



WARNING

1. Never touch any rotating motor parts while the motor is running.
Doing so may result in injury.
2. DO NOT touch the inside the driver.
Doing so may result in electric shock.
3. Do not remove the panel cover while the power is ON.
Doing so may result in electric shock.
4. Do not touch terminals for five minutes after the power has been turned OFF.
Residual voltage may cause electric shock.



CAUTION

1. Conduct trial operation on the servomotor alone with the motor shaft disconnected from machine to avoid any unexpected accidents.
Not doing so may result in injury.
2. Before starting operation with a machine connected, change the settings to match the parameters of the machine.
Starting operation without matching the proper settings may cause the machine to run out of control or malfunction.
3. Before starting operation with a machine connected, make sure that an emergency stop can be applied at any time.
Not doing so may result in injury.
4. Do not touch the heat sinks during operation.
Not doing so may result in burns due to high temperatures.
5. Do not attempt to change wiring while the power is ON.
Doing so may result in electric shock or injury

Content

Preface.....	I
Constitution of This Manual.....	I
Intended User.....	I
How to Fetch This Manual.....	I
1 Checking Product and Part Names.....	1
1-1. Checking Products on Delivery.....	1
1-1-1. Servomotors.....	1
1-1-2. Servo Drivers.....	2
1-2. Product Part Names.....	2
1-2-1. Servomotors.....	2
1-2-2. Servo Drivers.....	2
2 Installation.....	5
2-1. Servomotor.....	5
2-1-1. Storage Temperature.....	5
2-1-2. Installation Site.....	5
2-1-3. Alignment.....	5
2-1-4. Orientation.....	6
2-1-5. Handling Oil and Water.....	6
2-1-6. Cable Stress.....	6
2-2. Servo Drivers.....	6
2-2-1. Storage Conditions.....	6
2-2-2. Installation Site.....	6
2-2-3. Orientation.....	7
2-2-4. Installation.....	7
3 Wiring.....	9
3-1. Main Circuit Wiring.....	9
3-1-1. Names and Descriptions of Main Circuit Terminal.....	9
3-1-2. Typical Wiring Example.....	10
3-1-3. Winding Terminals On Servomotor.....	10
3-2. I/O Signals.....	10
3-2-1. Layout Of CNO/CN1 Terminals.....	10
3-2-2. CNO and CN1 Signal Names and Functions.....	11
3-2-3. I/O Signal Names and Functions.....	11
3-2-4. Interface Circuits.....	12
3-3. Wiring Encoders.....	13
3-3-1. Encoder Connections.....	13
3-3-2. CN2 Encoder Connector Terminal Layout.....	13
3-4. Examples Of Standard Connections.....	14
3-4-1. Position Control Mode.....	14
3-5. Communication Port.....	15
3-5-1. Serial Port 1(COM1).....	15
3-5-2. Serial Port 2(COM2).....	16
3-6. Regenerative Resistor.....	16
4 Parameter Settings and Functions.....	18
4-1. List Of Parameters.....	18
4-1-1. Functions P0.....	18
4-1-2. Control Parameters P1.....	19
4-1-3. Position Control Parameter P2.....	19
4-1-4. Speed Control Parameter P3.....	20
4-1-5. Torque Control Parameter P4.....	20
4-1-6. Signal Settings P5.....	20
4-1-7. Modbus Address.....	23
4-2. Settings According to Equipment Characteristics.....	25
4-2-1. Switching Rotation Direction.....	25
4-2-2. Overtravel Limit (P-OT & N-OT).....	25
4-2-3. Servo OFF Stop Mode.....	27
4-2-4. Torque Limit.....	27
4-2-5. Internal Speed Limit In Torque Control.....	28
4-2-6. Holding Brake (BK).....	28

4-3. Settings According to Host Controller.....	31
4-3-1. Speed Reference.....	31
4-3-2. Position Reference.....	31
4-3-3. I/O Signals.....	33
4-3-4. Electronic Gear.....	34
4-3-5. Digital Reference Speed Control.....	36
4-3-6. Torque Control.....	38
4-3-7. Encoder Z Signal Output.....	38
4-4. Setting Up the Servo Driver.....	39
4-4-1. Indicating Control Mode.....	39
4-4-2. Input Signal Assignment.....	40
4-4-3. Output Signal Assignment.....	40
4-4-4. Jog Speed.....	41
4-5. Setting Stop Functions.....	41
4-5-1. Zero Clamp (/ZCLAMP).....	41
4-6. IO Signals Control.....	42
4-6-1. Alarm Output (/ALM).....	42
4-6-2. Servo ON Input (S-ON).....	43
4-6-3. Positioning Completed Output (/COIN).....	43
4-6-4. Speed Coincidence Output (/V-CMP).....	45
4-6-5. Rotation Detection Output (/TGON).....	45
4-6-6. Servo Ready Output (/S-RDY).....	46
4-6-7. Near Output (/NEAR).....	47
4-6-8. Warning Output (WARN).....	48
4-7. Smooth Operation.....	49
4-7-1. Smoothing.....	49
4-7-2. Soft Start Function.....	50
4-8. Gain Adjustments.....	50
4-8-1. Servo Gain Parameters.....	50
4-8-2. Using Proportional Control (/P-CON).....	51
4-8-3. Gain Selection (/G-SEL).....	52
5 Using Digital Panel.....	53
5-1. Basic Operation.....	53
5-1-1. Functions Of Digital Panel.....	53
5-1-2. Basic Mode Selection.....	53
5-2. Status Display Mode.....	54
5-3. Monitor Mode.....	56
5-4. Auxiliary Function.....	57
5-4-1. Check System Infomation.....	58
5-4-2. Auxiliary Run Mode.....	58
5-4-3. Set Motor Code.....	59
5-4-4. Check Alarm Information.....	59
5-4-5. Reset Parameters To Default.....	60
5-4-6. External Communication.....	60
5-5. Parameter Setting.....	60
5-6. Alarm.....	61
6 Ratings and Characteristics.....	62
6-1. Servomotors.....	62
6-1-1. Servomotor Ratings and Specifications.....	62
6-1-2. Torque-Speed Feature.....	63
6-1-3. Servomotors Dimensions.....	63
6-2. Servo Drivers.....	67
6-2-1. Ratings.....	67
6-2-2. Specifications.....	67
6-2-3. Servo Drivers Dimensions.....	68
7 Alarm Information.....	71

Preface

This chapter describes the constitution of this manual, the intended user, and how to acquire this manual.

Constitution of This Manual

This manual is divided into 7 chapters.

1. Checking Product and Part Names

This chapter describes the procedure for checking products upon delivery as well as names for product parts.

2. Installation

This chapter describes precautions for servomotor and servo driver installation.

3. Wiring

This chapter describes the procedure used to connect DS2 Series products to peripheral devices and gives typical examples of main circuit wiring as well as I/O signal connections.

4. Parameter Settings and Functions

This chapter describes the procedure for setting and applying parameters.

5. Use Digital Panel

This chapter describes the basic operation of the digital panel and the features it offers.

6. Ratings and Characteristics

This chapter provides the ratings, torque-speed characteristics diagrams, and dimensional drawings of the DS2 series servo drives and MS series servomotors.

7. Alarm Information

This chapter describes the alarm information of DS2 series servo drivers.

Intended User

This manual is intended for the following users.

- Those designing DS2 Series servodrive systems.
- Those installing or wiring DS2 Series servodrives.
- Those performing trial operation or adjustments of DS2 Series servodrives.
- Those maintaining or inspecting DS2 Series servodrives.

How to Acquire This Manual

1. Electrical Manual

- (2) Acquire this manual on a CD from an authorized distributor.

1 Checking Product and Part Names

This chapter describes the procedure for checking products upon delivery as well as names for product parts.

1-1. Checking Products on Delivery

Use the following checklist when products are delivered.

Initial Inspection	Comments
Are the delivered products the ones that were ordered?	Check the model numbers marked on the nameplates of the servomotor and servo driver.
Does the servomotor shaft rotate smoothly?	The servomotor shaft is normal if it can be turned smoothly by hand. Servomotors with brakes, however, cannot be turned manually.
Is there any damage?	Check the overall appearance, and check for damage or scratches that may have occurred during shipping.
Are there any loose screws?	Check screws for looseness using a screwdriver.
Is the motor code the same with the code in driver?	Check the motor code marked on the nameplates of the servomotor and the parameter F0-00 on the servo driver.

If any of the above are faulty or incorrect, contact Xinje or an authorized distributor.

1-1-1. Servomotors

■ External Appearance

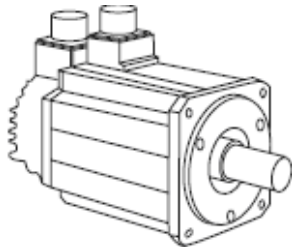

■ Nameplate

MS -80 ST - M 02430 A Z - 2 0P7

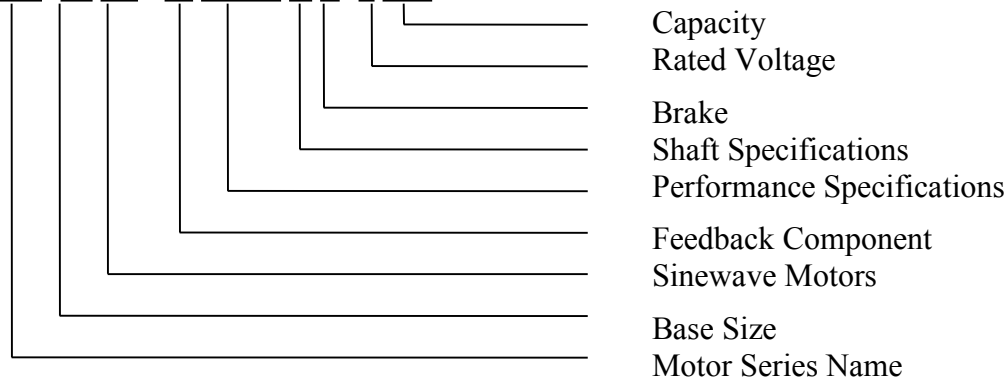

Base Size: 60, 80, 110, 130;

Feedback Component: M(Optical incremental encoder);

Performance Specifications: the first 3 decimals indicate the rated torque, and the last 2 decimals indicate the rated speed.

01330: Rated Torque 1.27N·m, Rated Speed 3000rpm

02430: Rated Torque 2.4N·m, Rated Speed 3000rpm;

- 04025: Rated Torque 4.0N·m, Rated Speed 2500rpm;
- 04030: Rated Torque 4.0N·m, Rated Speed 3000rpm;
- 05030: Rated Torque 5.0N·m, Rated Speed 3000rpm;
- 06025: Rated Torque 6.0N·m, Rated Speed 2500rpm;
- 10015: Rated Torque 10.0N·m, Rated Speed 1500rpm;

Shaft Specifications: A - With No Key; B - With A Key

Brake: Null - None; Z - With a DC99V Brake

Rated Voltage: 2 - 220V; 4 - 380V

Capacity: 0P4-0.4kW; 0P7-0.75kW; 1P5-1.5kW; 2P0 - 2.0kW

1-1-2. Servo Drivers

■ External Appearance

DS2-20P4
DS2-20P7

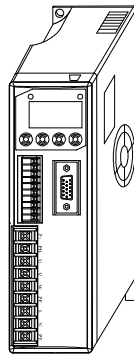

DS2-21P5

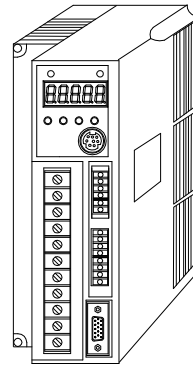

■ Nameplate

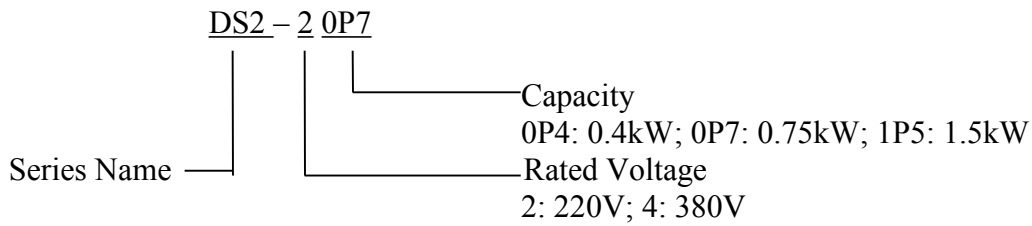

1-2. Product Part Names

1-2-1. Servomotors

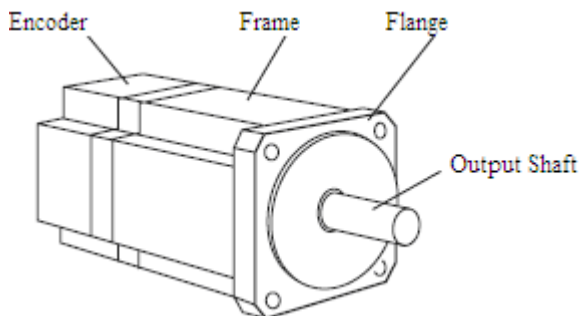

1-2-2. Servo Drivers

■ DS2-20P4, DS2-20P7

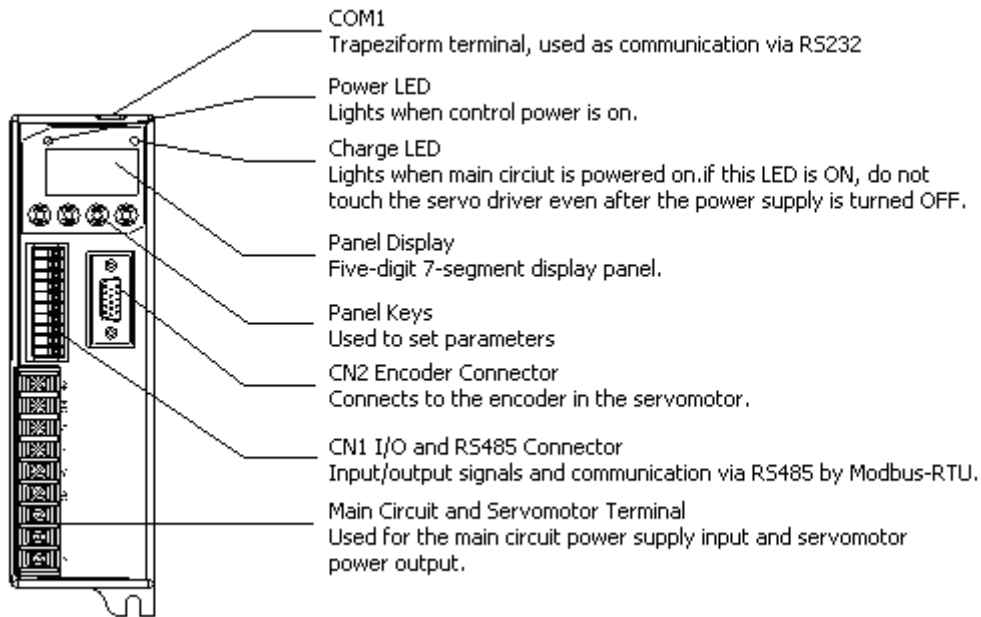

■ **DS2-21P5**

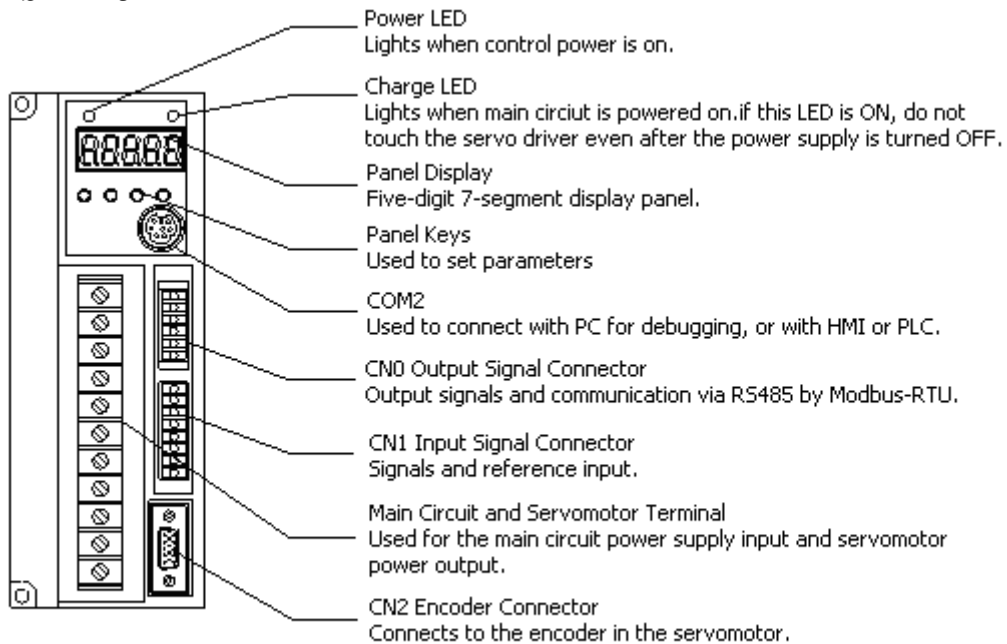

2 Installation

This chapter describes precautions for servomotor and servo driver installation.

2-1. Servomotor

MS series servomotors can be installed either horizontally or vertically. The service life of the servomotor can be shortened or unexpected problems might occur if it is installed incorrectly or in an inappropriate location. Follow these installation instructions carefully.



CAUTION

1. The end of the motor shaft is coated with anti-corrosive paint. Before installing, carefully remove all of the paint using a cloth moistened with paint thinner.
2. Avoid getting thinner on other parts of the servomotor.

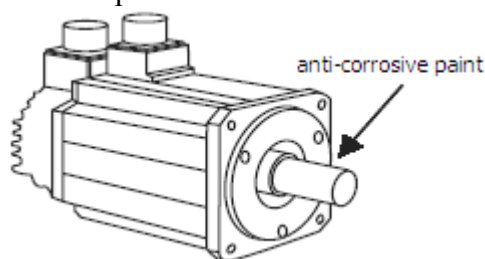

2-1-1. Storage Temperature

Store the servomotor within $-20\sim+60\text{ }^{\circ}\text{C}$ as long as it is stored with the power cable disconnected.

2-1-2. Installation Site

MS series servomotors are designed for indoor use. Install the servomotor in environments that satisfy the following conditions.

- Free of corrosive or explosive gases.
- Well-ventilated and free of dust and moisture.
- Ambient temperature of 0° to 50°C .
- Relative humidity (r.h.) of 20 to 80% with no condensation.
- Accessible for inspection and cleaning.

2-1-3. Alignment

Align the shaft of the servomotor with the shaft of the equipment, and then couple the shafts. Install the servomotor so that alignment accuracy falls within the following range.

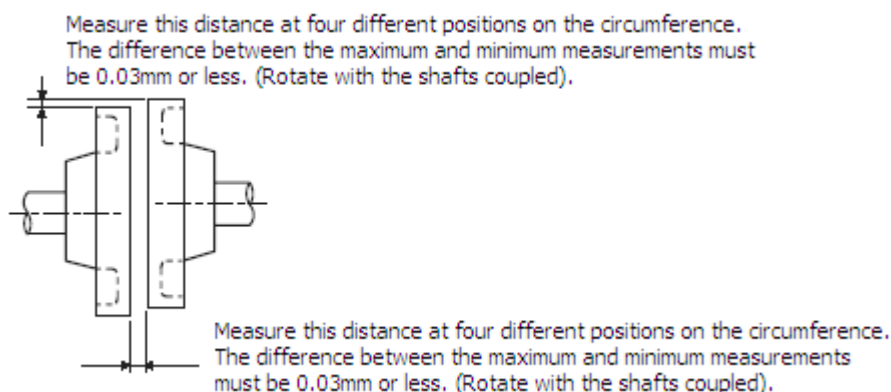

Note: (1) Vibration, which will damage the bearings, will occur if the shafts are not properly aligned.

(2) When installing the coupling, prevent direct impact to the shaft. This can damage the encoder mounted on the opposite end.

2-1-4. Orientation

MS series servomotors can be installed either horizontally or vertically.

2-1-5. Handling Oil and Water

Install a protective cover over the servomotor if it is used in a location that is subject to water or oil mist. Also use a servomotor with an oil seal when needed to seal the through-shaft section.

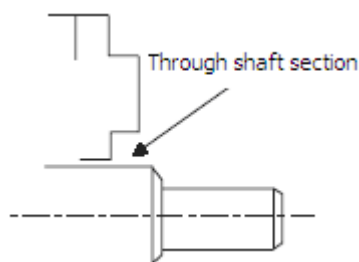

2-1-6. Cable Stress

Make sure that the power lines are free from bends and tension. Be especially careful to wire signal line cables so that they are not subject to stress because the core wires are very thin, measuring only 0.2 to 0.3mm².

2-2. Servo Drivers

The DS2 series servo drivers are base-mounted servo drivers. Incorrect installation will cause problems. Follow the installation instructions below

2-2-1. Storage Conditions

Store the servo driver within -20~+85°C, as long as it is stored with the power cable disconnected.

2-2-2. Installation Site

The following precautions apply to the installation site.

Situation	Installation Precaution
Installation in a Control Panel	Design the control panel size, unit layout, and cooling method so the temperature around the servo drivers does not exceed 50°C.

Installation Near a Heating Unit	Minimize heat radiated from the heating unit as well as any temperature rise caused by natural convection so the temperature around the servo drivers does not exceed 50°C.
Installation Near a Source of Vibration	Install a vibration isolator beneath the servo driver to avoid subjecting it to vibration.
Installation at a Site Exposed to Corrosive Gas	Corrosive gas does not have an immediate effect on the servo drivers, but will eventually cause electronic components and terminals to malfunction. Take appropriate action to avoid corrosive gas.
Other Situations	Do not install the servo driver in hot and humid locations or locations subject to excessive dust or iron powder in the air.

2-2-3. Orientation

Install the servo driver perpendicular to the wall as shown in the figure. The servo driver must be oriented this way because it is designed to be cooled by natural convection or by a cooling fan.

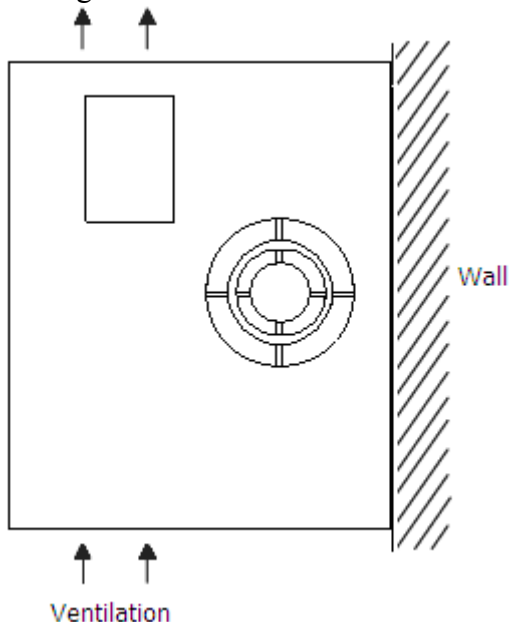

2-2-4. Installation

Follow the procedure below to install multiple servo drivers side by side in a control panel.

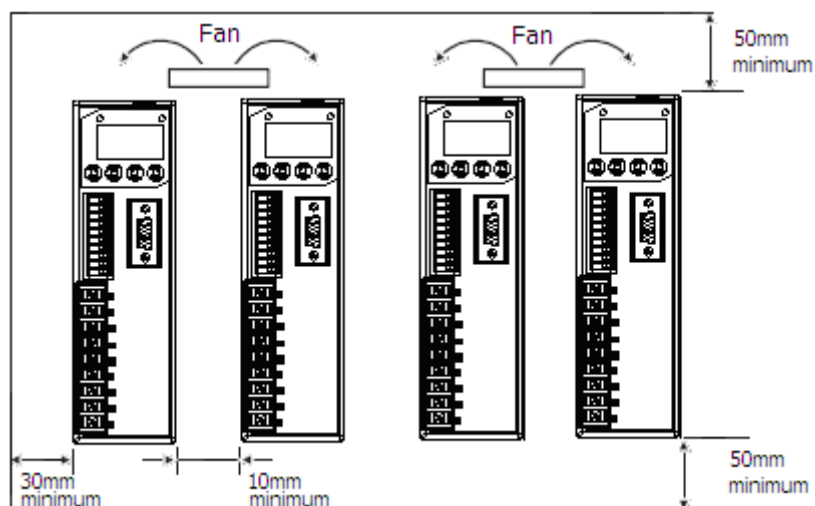

■ Servo Driver Orientation

Install the servo driver perpendicular to the wall so the front panel containing connectors faces outward.

■ Cooling

As shown in the figure above, allow sufficient space around each servo driver for cooling by cooling fans or natural convection.

■ Side-by-side Installation

When installing servo drivers side by side as shown in the figure above, allow at least 10mm between and at least 50mm above and below each servo driver. Install cooling fans above the servo drivers to avoid excessive temperature rise and to maintain even temperature inside the control panel.

■ Environmental Conditions in the Control Panel

- Ambient Temperature: 0~50 °C
- Humidity: 90%RH or less
- Vibration: 4.9m/s²
- Condensation and Freezing: None
- Ambient Temperature for Long-term Reliability: 45°C maximum

3 Wiring

This chapter describes the procedure used to connect DS2 Series products to peripheral devices and gives typical examples of main circuit wiring as well as I/O signal connections.

3-1. Main Circuit Wiring

This section shows typical examples of main circuit wiring for DS2 Series servo products, functions of main circuit terminals, and the power ON sequence.

Observe the following precautions when wiring.



Caution

1. Do not bundle or run power and signal lines together in the same duct. Keep power and signal lines separated by at least 11.81in(30cm)
2. Use twisted pair wires or multi-core shielded-pair wires for signal and encoder(PG) feedback lines.
The maximum length is 118.11in(3m) for reference input lines and is 787.40in(20m) for encoder(PG) feedback lines.
3. Do not touch the power terminals for 5 minutes after turning power OFF because high voltage may still remain in the servo amplifier.
Please make sure to check the wiring after the CHARGE light is going off.
4. Avoid frequently turning power ON and OFF. Do not turn power ON or OFF more than once per minute.
Since the servo amplifier has a capacitor in the power supply, a high charging current flows for 0.2s when power is turned ON. Frequently turning power ON and OFF causes main power devices like capacitors and fuses to deteriorate, resulting in unexpected problems.



3-1-1. Names and Descriptions of Main Circuit Terminal

The following table gives the names and a description of main circuit terminals on DS2-20P4、DS2-20P7 from the top down.

Symbol	Name	Description
P+、PB	External regenerative resistor terminal	Connect an external regenerative resistor between P+ and PB.
U、V、W	Servomotor connection terminal	Connects to the Servomotor.
	Ground terminal	Connects to the motor ground terminal.
L、N	Main circuit AC input terminal	Single-phase 200~240V, 50/60Hz
	Ground terminal	Connects to the power supply ground terminal.

The following table gives the names and a description of main circuit terminals on DS2-21P5 from the top down.

Symbol	Name	Description
	DC reactor terminal connection for power supply harmonic wave countermeasure	Normally short 1 and 2. If a countermeasure against power supply harmonic waves is needed, connect a DC reactor between 1 and 2.

L、N	Main circuit AC input terminal	Single-phase 200~240V, 50/60Hz
	Ground terminal	Connects to the motor ground terminal.
U、V、W	Servomotor connection terminal	Connects to the Servomotor.
	Ground terminal	Connects to the power supply ground terminal.
P+、PB	External regenerative resistor terminal	Connect an external regenerative resistor between P+ and PB.

3-1-2. Typical Wiring Example

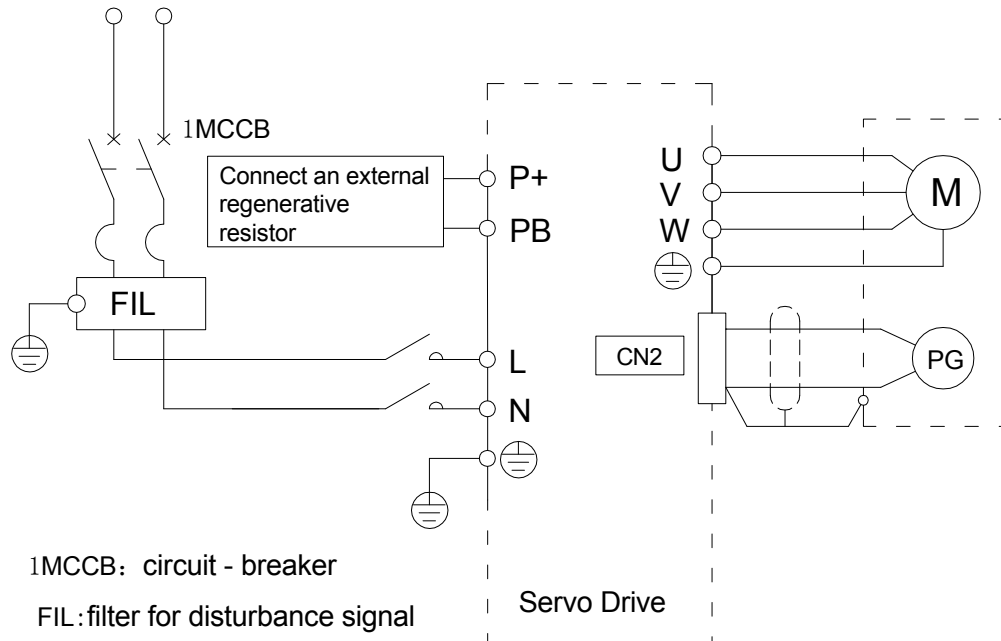

3-1-3. Winding Terminals On Servomotor

Symbol	60、80 Series	130 Series
PE	4	1
U	1	2
V	3	3
W	2	4

3-2. I/O Signals

This section describes I/O signals for the DS2 series servo driver.

3-2-1. Layout Of CN0/CN1 Terminals

DS2-20P4 and DS2-20P7 series	DS2-21P5 series	
Layout of CN1 terminals	Layout of CN0 terminals	Layout of CN1 terminals

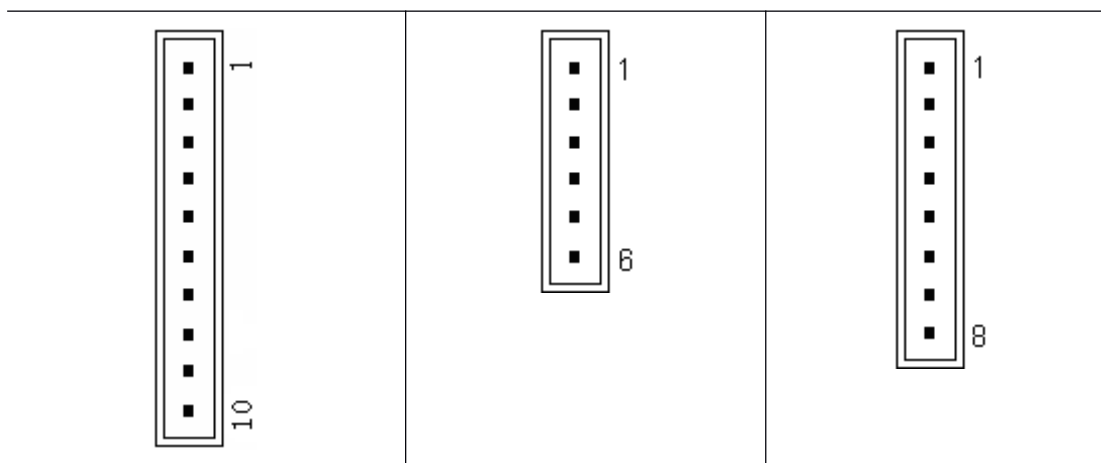

3-2-2. CN0 and CN1 Signal Names and Functions

■ CN0 Signal Names and Functions

No	Symbol	Description	No	Symbol	Description
1	SO1	Output Singal Terminal 1	4	COM	Output Singal Ground
2	SO2	Output Singal Terminal 2	5	A	RS485 +
3	SO3	Output Singal Terminal 3	6	B	RS485 -

■ CN1 Signal Names and Functions

(1) DS2-20P4 and DS2-20P7

No	Symbol	Description	No	Symbol	Description
1	A	RS485 +	6	SI2	Input Singal Terminal 2
2	B	RS485 -	7	+24V	+24V Used By Input Signals
3	PULS	Quadrature Pulse A, Or Pulse Signal	8	SO1	Output Singal Terminal 1
4	SIGN	Quadrature Pulse B, Or Sign Signal	9	SO2	Output Singal Terminal 2
5	SI1	Input Singal Terminal 1	10	COM	Output Singal Ground

(2) DS2-21P5

No	Symbol	Description	No	Symbol	Description
1	PULS	Quadrature Pulse A, Or Pulse Signal	5	SI2	Input Singal Terminal 2
2	SIGN	Quadrature Pulse B, Or Sign Signal	6	SI3	Input Singal Terminal 3
3	V+	+24V For PULS and SIGN	7	SI4	Input Singal Terminal 4
4	SI1	Input Singal Terminal 1	8	+24V	+24V For Input Signals

3-2-3. I/O Signal Names and Functions

The following section describes servo driver I/O signal names and functions.

■ Input Signals

Class	Name	Functions	Reference
Digital Input	SI1~SI4	Multi-functions Input Terminals	4-1-6、4-4-2
Pulse Input	PULS	P2-00=1: Quadrature Pulse A P2-00=2: Pulse Signal	4-3-2

	SIGN	P2-00=1: Quadrature Pulse B P2-00=2: Sign Signal	4-3-2
--	------	-----------------------------------------------------	-------

■ Output Signals

Class	Name	Functions	Reference
Digital Output	SO1~SO3	Multi-functions Output Terminals	3-2-4, 4-1-6, 4-4-3

3-2-4. Interface Circuits

This section shows examples of servo driver I/O signal connection to the host controller.

■ Interface for Reference Input Circuits

Reference Position Input Circuit

An output circuit for the reference position signal at the host controller can only be open-collector type.

- open-collector type(External power supply)

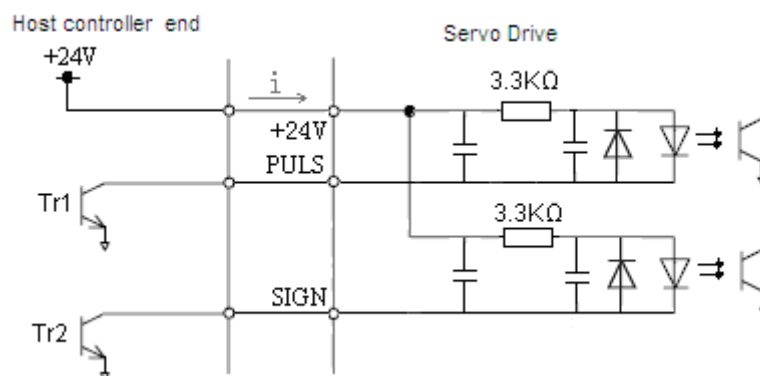

■ Input Signals Circuit Interface

The input signals circuit interface connects through a relay or open-collector transistor circuit. Select a low-current relay, otherwise a faulty contact will result.

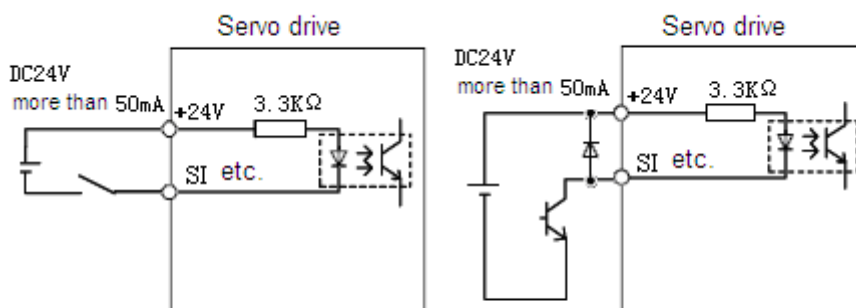

■ Output Signals Circuit Interface

Output signal terminals of servo driver can only be connected to an open-collector output circuit. Please refer to the host controller to connect output signals.

Connect to a photocoupler

Connect to a relay

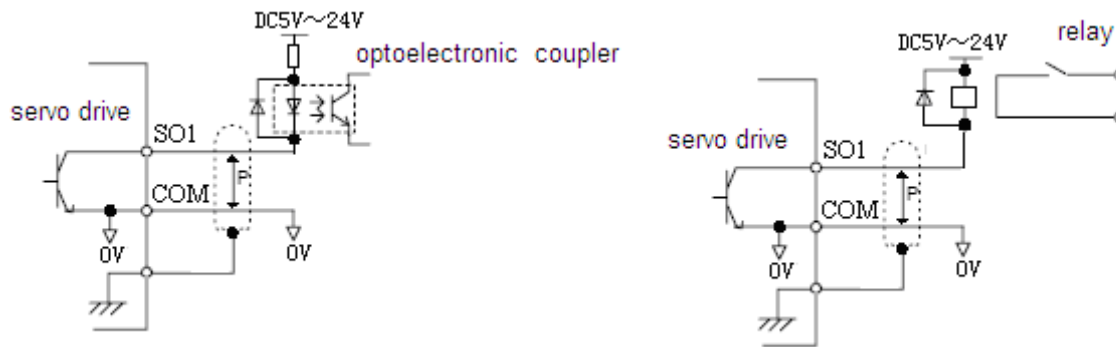

Note: The maximum allowable voltage and current capacities for open-collector circuits are:

Voltage: DC30V

Current: 50mA

3-3. Wiring Encoders

The following sections describe the procedure for wiring a servo driver to the encoder.

3-3-1. Encoder Connections

The following diagrams show the wiring of the encoder output from the motor to CN2 of the servo driver. This applies to only incremental encoders.

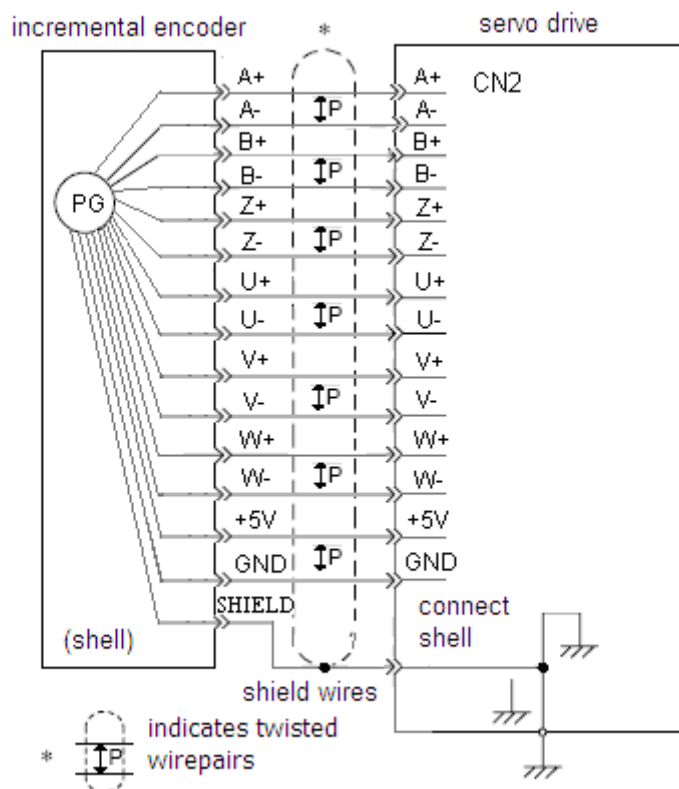

3-3-2. CN2 Encoder Connector Terminal Layout

■ CN2 Connector Terminal Layout

The following diagrams show the layout of CN2 connector(facing the solder pin).

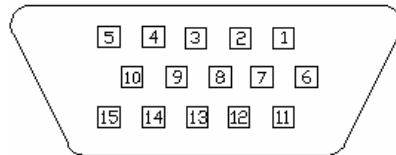

■ CN2 Connector Terminal Description

Driver Side	Encoder Side On Motor		Name	Driver Side	Encoder Side On Motor		Name
	60 and 80 series	110 and 130 series			60 and 80 series	110 and 130 series	
1	9	4	A+	2	4	5	B+
3	7	6	Z+	4	6	10	U+
5	11	12	W+	6	13	7	A-
7	14	8	B-	8	5	9	Z-
9	8	13	U-	10	15	15	W-
11	1	1	Shield	12	3	3	GND
13	2	2	5V	14	10	11	V+
15	12	14	V-				

3-4. Examples Of Standard Connections

The following diagrams show examples of standard servo driver connections by specifications and type of control.

The I/O signals used on input and output terminals are assigned by default. This assignment could be changed in various conditions. Please refer to 4-1-6.

3-4-1. Position Control Mode

■ DS2-20P4 and DS2-20P7

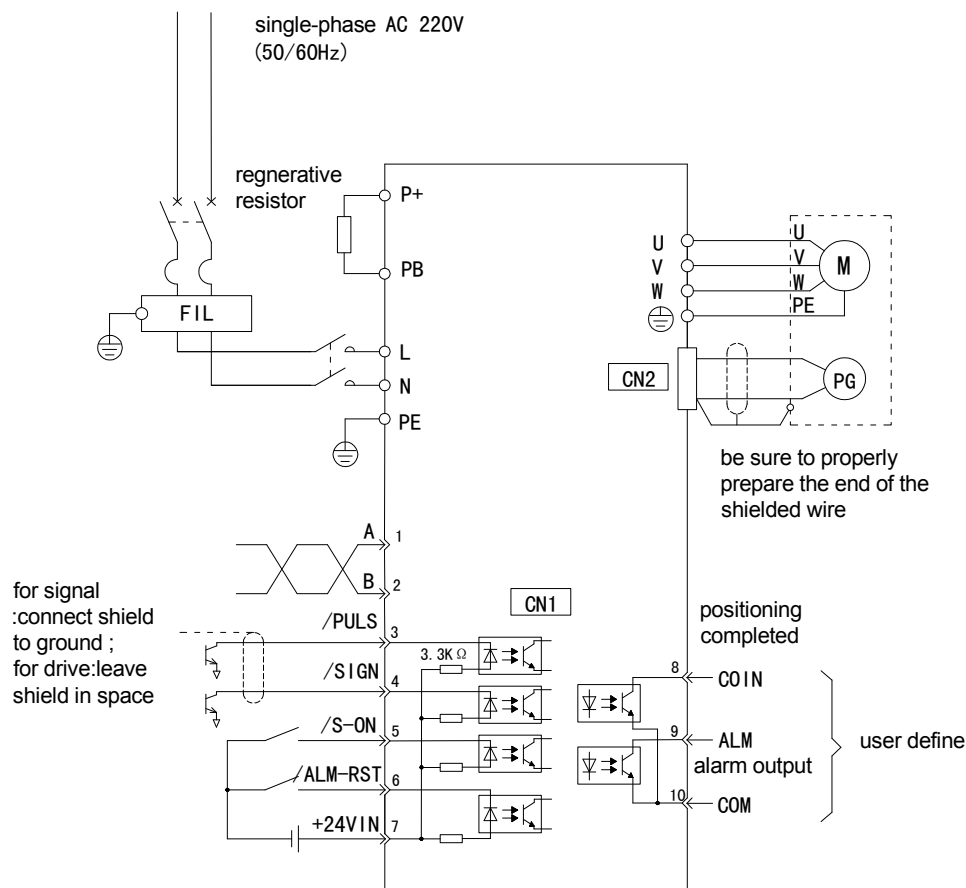

■ DS2-21P5

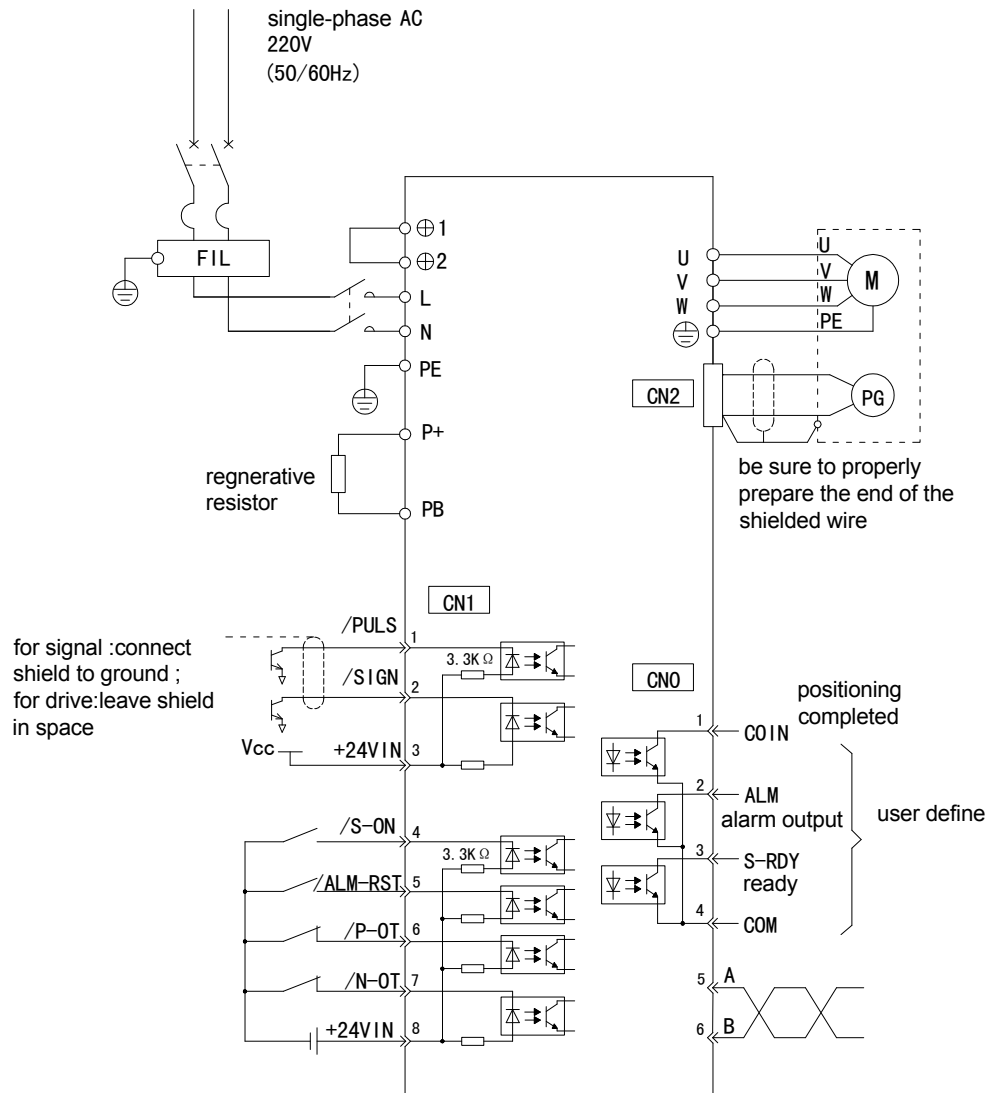

3-5. Communication Port

3-5-1. Serial Port 1(COM1)

COM1 supports RS232, and is often used to connected with PC for debugging. Before doing this, “F5-00” on the panel should be switched to “C-OUT”, and the panel will be invalidated. On leaving this status, use the panel to exit, and PC disconnect from servo driver. Please refer to 5-4-6.

Communication parameters of COM1 is fixed:

Baudrate: 19200bps; Data bits: 8 bits; Stop bits: 1 bit; Parity: even parity; Modbus station number: 1.

- DS2-20P4 and DS2-20P7 has a trapeziform terminal with 5 pins.



Number	Name	Description
1	TXD	RS232 TXD
2	RXD	RS232 RXD
3	GND	RS232 GND

Note: Please plug COM1 with special connector from Xinje.

- DS2-21P5 has a DB8 terminal.

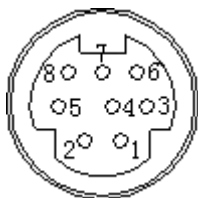

Number	Name	Description
2	UPGRADE	Self Upgrade
4	RXD	RS232 RXD
5	TXD	RS232 TXD
8	GND	RS232 GND

3-5-2. Serial Port 2(COM2)

COM2 supports RS485 and is placed to “A” and “B” terminals on CN0(DS2-21P5) or CN1(DS2-20P4 and DS2-20P7). It bases on Modbus-RTU protocol. Please refer to 3-2-1.

Communication parameters of COM2 can be set by P0-04.

Parameter Number	Name	Default Setting	Range
P0-04.0	Baudrate	6	0: 300 1: 600 2: 1200 3: 2400 4: 4800 5: 9600 6: 19200 7: 38400 8: 57600 9: 115200
P0-04.1	Data Bits	0	0: 8bits
P0-04.2	Stop Bits	2	0: 2bits. 2: 1bit
P0-04.3	Parity	2	0: No Parity. 1: Odd Parity. 2: Even Parity

Modbus station number can be set freely, depending on the following parameter.

Parameter Number	Name	Unit	Default Setting	Range
P0-03	Modbus Station Number	-	1	1~255

Note: Parameters above will take effect after power on.

3-6. Regenerative Resistor

When the servomotor operates in generator mode, power is returned to the servo driver side. This is called regenerative power. The regenerative power is absorbed by charging the smoothing capacitor, but when the capacitor's charging limit is exceeded, the regenerative power needs to be reduced by the regenerative resistor.

The servomotor is driven in regeneration (generator) mode in the following conditions:

- While decelerating to a stop during acceleration/deceleration operation.
- With a load on the vertical axis.
- During continuous operation with the servomotor driven from the load side (negative load).

Connecting Regenerative Resistors

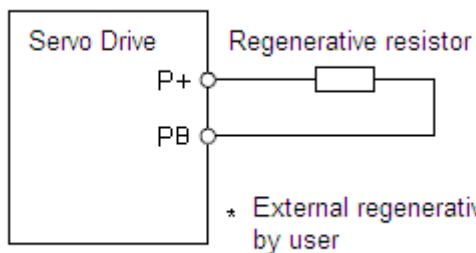

Connect an external regenerative resistor between P+ and PB.

* External regenerative resistor prepared by user

Note: Adequate cooling must be provided for regenerative resistors because they reach very high temperatures. Also use heat-resistant, non-flammable wire and make sure that the wiring does not come into contact with the resistors.

Motor Model	Recommended Resistance	Recommended Power	Minimum Resistance
MS-60ST-M01330□□-20P4	50Ω	100W	40Ω
MS-80ST-M02430□□-20P7	50Ω	100W	40Ω
MS-110ST-M06030□□-21P5	50Ω	100W	40Ω
MS-130ST-M10015□□-21P5	50Ω	300W	40Ω

Note: The *Recommended Power* means that the value may be suitable to most applications. Nevertheless, in some special conditions, actual power could be more or less than the recommended value, so the rated power should be flexible to actual temperature of the regenerative resistor.

4 Parameter Settings and Functions

This chapter describes the procedure for setting and applying parameters.

4-1. List Of Parameters

Time of taking effect: “○” Re-enable servo driver

“●” Restart servo driver

“√” Be effective at any time

A hex parameter has a prefix “n.” denoting this parameter is a hex value.

Composing of a parameter: PX-XX = $\begin{matrix} n.xx & xx \\ \swarrow & \searrow \\ & \end{matrix}$

PX-XX.H

PX-XX.L

4-1-1. Functions P0

Modbus Address: 0x0000~0x00FF

P0	Name	Unit	Default Setting	Setting Range	Time of Taking Effect	Reference
-						
00	Main Mode	-	0	0	○	4-4-1
01	Sub Mode 1 0: Idle 1: Torque (Digital Reference) 2: Torque (Analog Reference) 3: Speed (Digital Reference) 4: Speed (Analog Reference) 5: Position (Digital Reference) 6: Position (Pulse Reference) 7: Speed (Pulse Reference)	-	0	0~7	○	4-4-1
02	Sub Mode 2 0~7 Same as above	-	0	0~7	○	4-4-1
03	Modbus station number of COM2	-	1	1~255	●	3-5-2
04	Communication parameters of COM2	-	n.2206	n.0000~n.2209	●	3-5-2
05	Rotation Direction	-	0	0, 1	●	4-2-1
06	06.L: Servo OFF Stop Mode DS2 series servo driver is fixed with “Coasts the servomotor to a stop”.	-	2	0~2	●	4-2-2
	06.H: Overtravel Stop Mode 0~1: Coasts the servomotor to a stop. 2: Decelerates the servomotor to a stop at the preset torque, and then locks the servomotor in Zero Clamp Mode. Torque setting: P4-06 Emergency Stop Torque. 3: Decelerates the servomotor to	-	2	0~3	●	4-2-3

	a stop at the preset torque, and puts the servomotor in coast status. Torque setting: P4-06 Emergency Stop Torque.					
07	T-REF Assignment Not available to DS2 series servo driver.	-	0	0~3	○	
08	V-REF Assignment Not available to DS2 series servo driver.	-	0	0, 1	○	

4-1-2. Control Parameters P1

Modbus Address: 0x0100~0x01FF

P1-	Name	Unit	Default Setting	Setting Range	Time of Taking Effect	Reference
00	Speed Loop Gain	1Hz	100	1~5000	√	4-8-1
01	Speed Loop Integral Time Contant	0.1ms	400	1~5000	√	4-8-1
02	Position Loop Gain	1/s	30	1~2000	√	4-8-1
03	Reserved					
04	2nd Speed Loop Gain	1Hz	150	1~5000	√	4-8-3
05	2nd Speed Loop Integral Time Contant	0.1ms	100	1~5000	√	4-8-3
06	2nd Position Loop Gain	1/s	80	1~2000	√	4-8-3
07	Reserved					
08	Reserved					
09	Position Loop Feed Forward	1%	0	0~100	√	4-3-2
10	Position Loop Feed Forward Filter Time Contant	0.01ms	0	0~65535	√	

4-1-3. Position Control Parameter P2

Modbus Address: 0x0200~0x02FF

P2-	Name	Unit	Default Setting	Setting Range	Time of Taking Effect	Reference
00	Input Pulse Form	-	2	1, 2	●	4-3-2
01	Position Reference Filter Type	-	0	0, 1	●	4-7-1
02	Electronic Gear Ratio (Numerator)	-	1	1~65535	○	4-3-4
03	Electronic Gear Ratio (Denominator)	-	1	1~65535	○	4-3-4
04	Position Reference Filter Time Contant	ms	0	0~100	●	4-7-1
05	Reserved					
06	Pulse Frequency On Rated Speed	100Hz	5000	1~10000	○	4-3-1
07	Pulse Filter Time Contant Of Speed Control	0.1ms	20	0~1000	√	4-3-1

4-1-4. Speed Control Parameter P3

Modbus Address: 0x0300~0x03FF

P3-	Name	Unit	Default Setting	Setting Range	Time of Taking Effect	Reference
00	Input Voltage On Rated Speed	0.01V	1000	150~3000	○	4-3-1
01	Speed 1	rpm	100	-5000~+5000	√	4-3-5
02	Speed 2	rpm	200	-5000~+5000	√	4-3-5
03	Speed 3	rpm	300	-5000~+5000	√	4-3-5
04	JOG Speed	rpm	100	0~1000	√	4-4-4
05	Acceleration Time	ms	0	0~65535	○	4-3-5
06	Deceleration Time	ms	0	0~65535	○	4-3-5
07	Speed Reference Filter Time Constant	0.01ms	0	0~65535	○	
08	Speed Feedback Filter Time Constant	0.01ms	20	0~65535	○	
09	Maximum Speed Limit	rpm	Rated Speed 3000: 4000 Rated Speed 1500: 2000	0~5000	○	

4-1-5. Torque Control Parameter P4

Modbus Address: 0x0400~0x04FF

P4-	Name	Unit	Default Setting	Setting Range	Time of Taking Effect	Reference
00	Input Voltage On Rated Torque	0.01V	1000	150~3000	○	4-3-6
01	Torque Reference Filter Time Constant	0.01ms	0	0~65535	○	
02	Forward Torque Limit	1%	300	0~300	√	4-2-4
03	Reverse Torque Limit	1%	300	0~300	√	4-2-4
04	Forward External Torque Limit	1%	100	0~300	√	4-2-4
05	Reverse External Torque Limit	1%	100	0~300	√	4-2-4
06	Emergency Stop Torque	1%	300	0~300	○	4-2-2
07	Speed Limit during Torque Control	rpm	2000	0~5000	○	4-2-5
08	Reserved					
09	Torque Digital Reference	1%	0	-300~300	√	4-3-6

4-1-6. Signal Settings P5

Modbus Address: 0x0500~0x05FF

P5-	Name	Unit	Default Setting	Setting Range	Time of Taking Effect	Reference
-----	------	------	-----------------	---------------	-----------------------	-----------

					ng Effect	
00	Positioning Completed Width /COIN	ref unit	7	0~250	○	4-6-3
01	Zero Clamp Speed Level /ZCLAMP	rpm	10	0~300	○	4-5-2
02	Rotation Detection Speed Level /TGON	rpm	20	1~1000	○	4-6-5
03	Speed Coincidence Signal Output Width /V-CMP	rpm	10	1~250	○	4-6-4
04	Positioning Nearing Signal Width /NEAR	ref unit	50	0~10000	○	4-6-7
05	Position Error Overflow Level	256 ref unit	1000	0~65535	○	4-8-1
06	Delay Time from Brake Output to Servo OFF	1ms	0	0~500	○	4-2-6
07	Brake Output Speed Limit	rpm	100	0~5000	○	4-2-6
08	Brake Output Time Limit	1ms	500	10~1000	○	4-2-6
09	Input Terminal Filter Time	5ms	0	0~100	√	
10	/S-ON Servo On n.0000: Signal is fixed to “OFF”. n.0001: Input from SI1. n.0002: Input from SI2. n.0003: Input from SI3. n.0004: Input from SI4. n.0010: Signal is fixed to “ON” n.0011: Input from SI1, reversed. n.0012: Input from SI2, reversed. n.0013: Input from SI3, reversed. n.0014: Input from SI4, reversed.	-	n.0001	n.0000~ n.0012 ※1	●	4-6-2
11	/P-CON Proportional Control Same As Above	-	n.0000	n.0000~ n.0012 ※1	●	4-8-2
12	/P-OT Forward Prohibited Same As Above	-	n.0000 ※3	n.0000~ n.0012 ※1	●	4-2-2
13	/N-OT Reverse Prohibited Same As Above	-	n.0000 ※4	n.0000~ n.0012 ※1	●	4-2-2
14	/ALM-RST Alarm Reset Same As Above	-	n.0000	n.0000~ n.0012 ※1	●	4-6-1
15	/P-CL Forward External Torque Limit Same As Above	-	n.0000	n.0000~ n.0012 ※1	●	4-2-4
16	/N-CL Reverse External Torque Limit Same As Above	-	n.0000	n.0000~ n.0012 ※1	●	4-2-4
17	/SPD-D	-	n.0000	n.0000~	●	4-3-5

	Digital Reference Speed Selection Same As Above			n.0012 ※1		
18	/SPD-A Digital Reference Speed Selection Same As Above	-	n.0000	n.0000~ n.0012 ※1	●	4-3-5
19	/SPD-B Digital Reference Speed Selection Same As Above	-	n.0000	n.0000~ n.0012 ※1	●	4-3-5
20	/C-SEL Control Mode Selection Same As Above	-	n.0000	n.0000~ n.0012 ※1	●	4-4-1
21	/ZCLAMP Zero Clamp Same As Above	-	n.0000	n.0000~ n.0012 ※1	●	4-5-2
22	/INHIBIT Pulse Inhibit Same As Above		n.0000	n.0000~ n.0012 ※1	●	
23	/G-SEL Gain Selection Same As Above	-	n.0000	n.0000~ n.0012 ※1	●	4-8-3
24	/CLR Pulse Error Clear Same As Above	-	n.0000	n.0000~ n.0012 ※1	●	4-3-2
25	Reserved					
26	Reserved					
27	Reserved					
28	/COIN Positioning Completed n.0000: Do not output. n.0001: Output to SO1. n.0002: Output to SO2. n.0003: Output to SO3. n.0011: Output to SO1, reversed. n.0012: Output to SO2, reversed. n.0013: Output to SO3, reversed.	-	n.0001	n.0000~ n.0012 ※2	●	4-6-3
29	/V-CMP Speed Coincidence Same As Above	-	n.0000	n.0000~ n.0012 ※2	●	4-6-4
30	/TGON Rotation Detection Same As Above	-	n.0000	n.0000~ n.0012 ※2	●	4-6-5
31	/S-RDY Servo Ready Same As Above	-	n.0000 ※5	n.0000~ n.0012 ※2	●	4-6-6
32	/CLT Torque Limit Reached Same As Above	-	n.0000	n.0000~ n.0012 ※2	●	4-2-4
33	/VLT Speed Limit Reached Same As Above	-	n.0000	n.0000~ n.0012 ※2	●	4-2-5
34	/BK	-	n.0000	n.0000~	●	4-2-6

	Brake Same As Above			n.0012 ※2		
35	/WARN Warn Same As Above	-	n.0000	n.0000~ n.0012 ※2	●	4-6-8
36	/NEAR Positioning Nearing Same As Above	-	n.0000	n.0000~ n.0012 ※2	●	4-6-7
37	/ALM Alarm Same As Above	-	n.0002	n.0000~ n.0012 ※2	●	4-6-1
38	/Z Encoder Z Signal Same As Above		n.0000	n.0000~ n.0012 ※2	●	4-3-7

※1: Setting range of DS2-21P5 is “n.0000~n.0014”.

※2: Setting range of DS2-21P5 is “n.0000~n.0013”.

※3: Default setting of DS2-21P5 is “n.0013”.

※4: Default setting of DS2-21P5 is “n.0014”.

※5: Default setting of DS2-21P5 is “n.0003”.

4-1-7. Modbus Address

All of the Modbus address are presented in hex.

■ Parameter Address

Parameter Number	Modbus Address	Parameter Number	Modbus Address	Parameter Number	Modbus Address	Parameter Number	Modbus Address
P0-00	0x0000	P1-00	0x0100	P2-00	0x0200	P3-00	0x0300
P0-01	0x0001	P1-01	0x0101	P2-01	0x0201	P3-01	0x0301
P0-02	0x0002	P1-02	0x0102	P2-02	0x0202	P3-02	0x0302
P0-03	0x0003	P1-03	0x0103	P2-03	0x0203	P3-03	0x0303
P0-04	0x0004	P1-04	0x0104	P2-04	0x0204	P3-04	0x0304
P0-05	0x0005	P1-05	0x0105	P2-05	0x0205	P3-05	0x0305
P0-06	0x0006	P1-06	0x0106	P2-06	0x0206	P3-06	0x0306
P0-07	0x0007	P1-07	0x0107	P2-07	0x0207	P3-07	0x0307
P0-08	0x0008	P1-08	0x0108			P3-08	0x0308
		P1-09	0x0109			P3-09	0x0309
		P1-10	0x010A				
Parameter Number	Modbus Address	Parameter Number	Modbus Address	Parameter Number	Modbus Address	Parameter Number	Modbus Address
P4-00	0x0400	P5-00	0x0500	P5-13	0x050D	P5-26	0x051A
P4-01	0x0401	P5-01	0x0501	P5-14	0x050E	P5-27	0x051B
P4-02	0x0402	P5-02	0x0502	P5-15	0x050F	P5-28	0x051C
P4-03	0x0403	P5-03	0x0503	P5-16	0x0510	P5-29	0x051D
P4-04	0x0404	P5-04	0x0504	P5-17	0x0511	P5-30	0x051E
P4-05	0x0405	P5-05	0x0505	P5-18	0x0512	P5-31	0x051F
P4-06	0x0406	P5-06	0x0506	P5-19	0x0513	P5-32	0x0520
P4-07	0x0407	P5-07	0x0507	P5-20	0x0514	P5-33	0x0521
P4-08	0x0408	P5-08	0x0508	P5-21	0x0515	P5-34	0x0522
P4-09	0x0409	P5-09	0x0509	P5-22	0x0516	P5-35	0x0523

		P5-10	0x050A	P5-23	0x0517	P5-36	0x0524
		P5-11	0x050B	P5-24	0x0518	P5-37	0x0525
		P5-12	0x050C	P5-25	0x0519	P5-38	0x0526

■ Monitor Address

Description	Modbus Address	Description	Modbus Address
Current Speed	0x0700	Current Alarm Code	0x0716
Speed Reference	0x0701	Current Warn Code	0x0717
Torque Reference	0x0702	Alarm/Warn Code Histry 1	0x0718
Angle(Mechanical Angle)	0x0703	U Current when Alarm raised	0x0719
Angle(Electrical Angle)	0x0704	V Current when Alarm raised	0x071A
DC Voltage	0x0705	DC Voltage when Alarm raised	0x071B
Temperature	0x0706	Temperature when Alarm raised	0x071C
Input Pulse Speed	0x0707	Speed when Alarm raised	0x071D
Pulse Error(Low Word)	0x0708	Torque when Alarm raised	0x071E
Pulse Error(High Word)	0x0709	V-REF when Alarm raised	0x071F
Position In One Circle (Low Word)	0x070A	T-REF when Alarm raised	0x0720
Position In One Circle (High Word)	0x070B	Alarm/Warn Code Histry 2	0x0728
Pulse Input(Low Word)	0x070C	Alarm/Warn Code Histry 3	0x0729
Pulse Input(High Word)	0x070D	Alarm/Warn Code Histry 4	0x072A
Pulse Feedback(Low Word)	0x070E	Alarm/Warn Code Histry 5	0x072B
Pulse Feedback(High Word)	0x070F	Alarm/Warn Code Histry 6	0x072C
Total Position(Low Word)	0x0710	Alarm/Warn Code Histry 7	0x072D
Total Position(High Word)	0x0711		
Current Current	0x0712		
V-REF Voltage	0x0713		
T-REF Voltage	0x0714		

■ Input Signals

Description	Modbus Address	Description	Modbus Address
/S-ON	0x0800	/SPD-A	0x0808
/P-CON	0x0801	/SPD-B	0x0809
/P-OT	0x0802	/C-SE	0x080A
/N-OT	0x0803	/ZCLAMP	0x080B
/ALM-RST	0x0804	Undefined	0x080C
/P-CL	0x0805	/G-SEL	0x080D
/N-CL	0x0806	/CLR	0x080E
/SPD-D	0x0807		

■ Output Signals

Description	Modbus Address	Description	Modbus Address
/COIN	0x0812	/BK	0x0818
/V-CMP	0x0813	/WARN	0x0819
/TGON	0x0814	/NEAR	0x081A
/S-RDY	0x0815	/ALM	0x081B
/CLT	0x0816	/Z	0x081C
/VLT	0x0817		





4-2. Settings According to Equipment Characteristics

This section describes the procedure for setting parameters according to the dimensions and performance characteristics of the equipment used.

4-2-1. Switching Rotation Direction

The servo amplifier has a Reverse Rotation Mode that reverses the direction of servomotor rotation without rewiring. Forward rotation in the standard setting is defined as counterclockwise as viewed from the load.

With the Reverse Rotation Mode, the direction of servomotor rotation can be reversed without changing other parameters. Only the direction of shaft motion is reversed.

	Standard Setting	Reverse Rotation Mode
Forward Reference		
Reverse Reference		

■ Setting Reverse Rotation Mode

Use the parameter P0-05 to reverse the rotation direction.

Parameter	Name	Unit	Setting Range	Default Setting
P0-05	Rotation Direction	-	0, 1	0

P0-05	Description	
0	Forward rotation is defined as counterclockwise (CCW) rotation as viewed from the load.	(Standard Setting)
1	Forward rotation is defined as clockwise (CW) rotation as viewed from the load.	(Reverse Rotation Mode)

Note: This parameter could not take effect until restart servo driver.

4-2-2. Overtravel Limit(P-OT & N-OT)

The overtravel limit function forces movable equipment parts to stop if they exceed the allowable range of motion.

■ Using the Overtravel Function

To use the overtravel function, connect the overtravel limit switch input signal terminals shown below to the servo driver CN1 connector.

Input Signal	Name	Control Mode
/POT	Forward Prohibited	Speed, Torque and Position Control
/NOT	Reverse Prohibited	Speed, Torque and Position Control

Connect limit switches as shown below to prevent damage to the devices during linear motion.

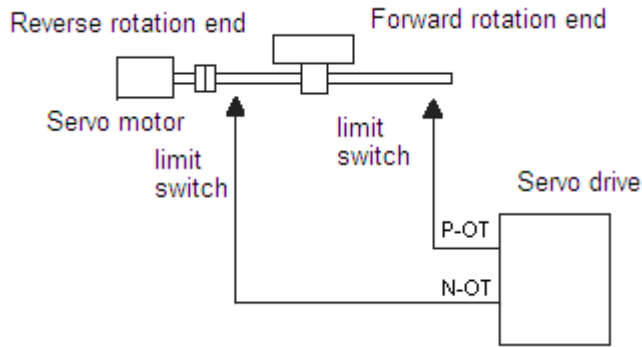

■ Enabling/Disabling Overtravel Function

Set the following parameters to specify whether input signals are used for overtravel or not. DS2-20P4 and DS2-20P7 is set to “not used”; DS2-21P5 is set to “used”.

Parameter	Description	Unit	Setting Range	Default Setting
P5-12	Always prohibit: P5-12 is set to n.0010, means always prohibit forward running. It is rarely used. Always not prohibit: P5-12 is set to n.0000, which means always allow running forward. Input from terminal: The last number of P5-12 is the terminal that input P-OT signal. The next number indicates if the signal is reversed, and “1” indicates the signal is reversed.	-	n.0000~ n.0012 ※1	n.0000 ※2
P5-13	Always prohibit: P5-13 is set to n.0010, means always prohibit forward running. It is rarely used. Always not prohibit: P5-13 is set to n.0000, which means always allow running forward. Input from terminal: The last number of P5-13 is the terminal that input P-OT signal. The next number indicates if the signal is reversed, and “1” indicates the signal is reversed.	-	n.0000~ n.0012 ※1	n.0000 ※3

※1: Setting range of DS2-21P5 is “n.0000~n.0014”.

※2: Default setting of DS2-21P5 is “n.0013”.

※3: Default setting of DS2-21P5 is “n.0014”.

Note: There would be superfluous pulse after stopped by overtravel function. Use clear signal(/CLR) to clear the pulse error.

■ Stop Mode for Overtravel

Set the following parameters to specify the Overtravel Stop Mode when P-OT and N-OT input signals are used.

Parameter	Name	Unit	Setting Range	Default Setting
P0-06.H	Overtravel Stop Mode	-	0~3	2

Setting Of P0-06.H	Description
0	Coasts the servomotor to a stop.
1	Coasts the servomotor to a stop.
2	Decelerates the servomotor to a stop at the preset torque, and then locks the servomotor in Zero Clamp Mode.

	Torque setting: P4-06 Emergency Stop Torque.
3	Decelerates the servomotor to a stop at the preset torque, and puts the servomotor in coast status. Torque setting: P4-06 Emergency Stop Torque.

Note:

(1) When the overtravel signal becomes effective, servomotor is forced OFF if Overtravel Stop Mode is set to “0” and “1”, or motor is not forced OFF before it is stopped if Overtravel Stop Mode is set to “2”, or motor is not forced OFF until /S-ON is OFF if Overtravel Stop Mode is set to “3”.

(2) Servomotor stopping is qualified by rotation detection speed(Unit: rpm).

4-2-3. Servo OFF Stop Mode

DS2 series servo driver turn motor off under following condition:

- The Servo ON input signal (/S-ON) is OFF.
- A alarm is raised.
- Power is turned OFF.

Parameter	Description	Unit	Setting Range	Default Setting
P0-06.L	Servo OFF Stop Mode	-	0~2	2

Whatever P0-06.L is set, DS2 series servo driver always coasts the servomotor to a stop

4-2-4. Torque Limit

Torque limit function is enabled when servo driver is in either Position Mode or Speed Mode.

If current torque exceeds the limit, /CLT signal is set to “ON”.

Use the parameter P5-32 to select which terminal will output the /CLT signal.

Signal	Signal Status	Reverse Or Not	Terminal Status	Description
/CLT (P5-32)	ON	Direct Output	On between SO and COM	Exceed limit
		Reverse Output	Off between SO and COM	
	OFF	Direct Output	On between SO and COM	Normal
		Reverse Output	Off between SO and COM	

Servo driver has 2 functions to limit torque as followed:

- Internal Torque Limit
- External Torque Limit

■ Internal Torque Limit(Maximum Torque For Output)

Internal Torque Limit function is used to limit the maximum torque by parameter when running in common.

Parameter	Name	Unit	Setting Range	Default Setting	Control Mode
P4-02	Forward Torque Limit	1%	0~300	300	Position Control, Speed Control
P4-03	Reverse Torque Limit	1%	0~300	300	Position Control, Speed Control

These settings are effective as long as servo being on (enabled). The unit is a percentage to the rated torque of a motor.

If torque limit is set higher than the maximum torque of the servomotor, the maximum torque of the servomotor is the limit.

The default setting is 300, which means 300% of rated torque.

Note: (1) If P4-02 or P4-03 is set much smaller, insufficient torque will be output when accelerating or decelerating.

(2) Maximum torque limit percentage may be different from various motors.

■ External Torque Limit(Limit Torque By Signal)

External torque limit function is used to limit the torque when motor moves into specified state, i.e, forcing stop and robot holding pieces.

Setting a torque percentage and then inputting a signal will take this function into effect.

Parameter	Name	Unit	Setting Range	Default Setting	Control Mode
P4-04	Forward External Torque Limit	1%	0~300	100	Position Control, Speed Control
P4-05	Reverse External Torque Limit	1%	0~300	100	Position Control, Speed Control

Note: The unit is a percentage to the rated torque of a motor.

4-2-5. Internal Speed Limit In Torque Control

Internal speed limit function is enabled in only torque control mode.

If current speed exceeds the limit, the /VLT signal is set to “ON”.

Signal	Output Status	Reverse Or Not	Terminal Status	Description
/VLT	ON	Direct Output	On between SO and COM	Exceed limit
		Reverse Output	Off between SO and COM	
	OFF	Direct Output	On between SO and COM	Normal
		Reverse Output	Off between SO and COM	

/VLT signal assignment can be modified by indicating the given parameter.

Parameter	Name	Unit	Setting Range	Default Setting
P5-33	Speed Limit Reached Assignment	-	n.0000~n.0012※1	n.0000

Default setting is n.0000, and /VLT doesn't assigned to any output terminal. Please refer to 4-3-3 to see how to set the signal assignment.

※1: Default setting of DS2-21P5 is “n.0013”.

■ Internal Speed Limit Level

Parameter	Name	Unit	Setting Range	Default Setting	Control Mode
P4-07	Speed Limit during Torque Control	rpm	0~5000	2000	Torque Control

4-2-6. Holding Brake (BK)

The holding brake is used when a servo driver controls a vertical axis. In other words, a servomotor with brake prevents the movable part from shifting due to the force of gravity when system power goes OFF.

	Brake Output to Servo OFF				Control and Torque Control
--	---------------------------	--	--	--	----------------------------

This parameter is used to set the output time from the brake control signal /BK until the servo OFF operation (servomotor output stop).

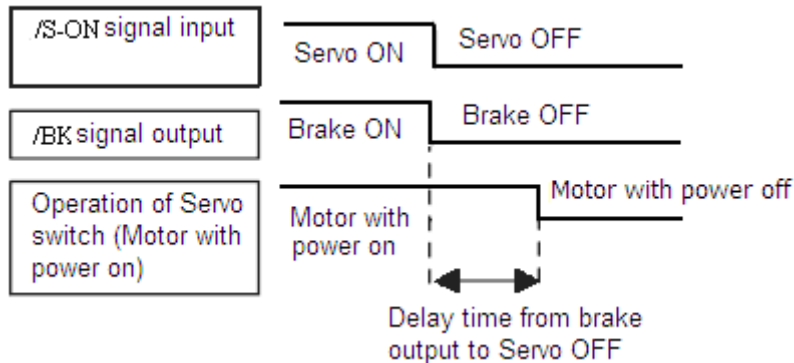

With the standard setting, the servo is turned OFF when the /BK signal (brake operation) is active. The equipment may move slightly due to gravity depending on equipment configuration and brake characteristics. If this happens, use this parameter to delay servo OFF timing.

This setting sets the brake ON timing when the servomotor is stopped.

■ Brake Output Timing (When Motor Is Rotating)

Set the following parameters to adjust brake ON timing so the holding brake is applied when the servo driver stops a rotating motor.

Parameter	Name	Unit	Setting Range	Default Setting	Control Mode
P5-07	Brake Output Speed Limit	rpm	0~5000	100	Position Control, Speed Control and Torque Control
P5-08	Brake Output Time Limit	1ms	10~1000	500	Position Control, Speed Control and Torque Control

Set the brake timing used when input signal /S-ON is turned OFF or when an alarm occurs during motor operation.

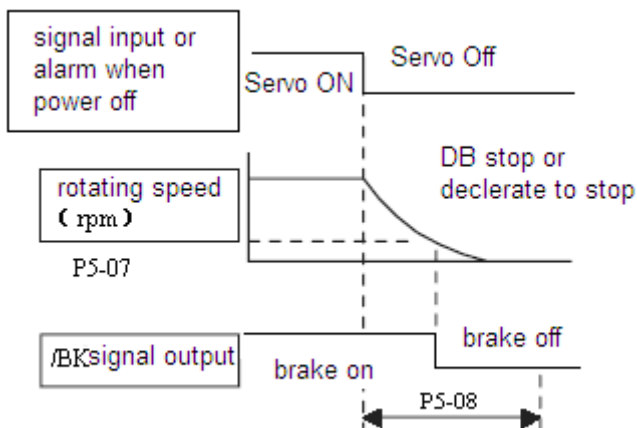

Brake ON timing when the servomotor stops must be adjusted properly because servomotor brakes are designed for holding position not for decelerating. Adjust the parameter settings while observing equipment operation.

The /BK signal is ON under either of the following conditions:

1. Motor speed drops below the setting at P5-07 after servo OFF.
2. The time set at P5-08 has elapsed since servo OFF.

The actual speed used will be the maximum speed even if P5-07 is set higher than the

maximum speed.

4-3. Settings According to Host Controller

4-3-1. Speed Reference

Input the speed reference using the input signal Speed Reference Input. Since this signal has various uses, set the optimum reference input for the system created.

■ Frequency Of Input Pulse Reference

Speed reference is in direct proportion to the frequency of input pulse string, and the reference is independent of the total number of the pulse string.

The circuit is the same as the circuit of position reference. The reference pulse form can be selected from “Quadrature Pulse Signal” and “Sign & Pulse Signal”.

Set the following parameter to indicate input pulse form.

Parameter	Name	Unit	Setting Range	Default Setting	Control Mode
P2-00	Input Pulse Form	-	1, 2	2	Position Control, Speed Control

Set reference pulse form input to the servo driver from the host controller.

Parameter	Setting	Input Pulse Form
P2-00	1	Quadrature Pulse Signal (multiplied 4)
	2	Sign & Pulse Signal

Set the following parameter to adjust the gain of frequency of input pulse.

Parameter	Name	Unit	Setting Range	Default Setting	Control Mode
P2-06	Pulse Frequency On Rated Speed	100Hz	1~10000	5000	Speed Control

Set the following parameter to adjust the filter time constant of frequency of input pulse.

Parameter	Name	Unit	Setting Range	Default Setting	Control Mode
P2-07	Pulse Filter Time Constant Of Speed Control	0.1ms	0~1000	20	Speed Control

4-3-2. Position Reference

The “Quadrature Pulse Signal” and “Sign & Pulse Signal” are used for the position reference. Since this signal can be used in different ways, set the optimum reference input for the system created.

■ Reference Pulse Input Circuit

Positioning is controlled by inputting a reference pulse for a move.

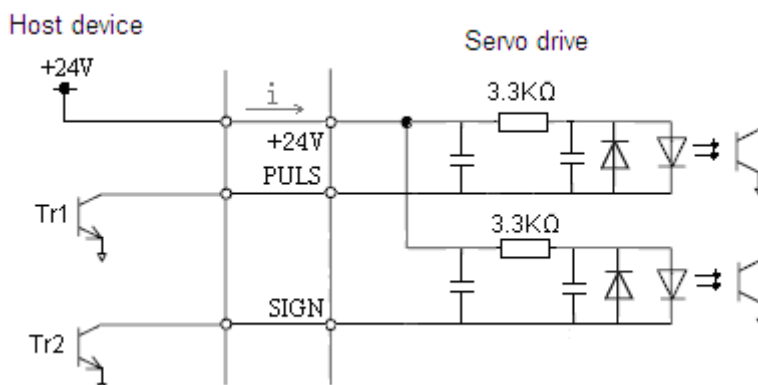

Note: The following table shows the signal logic for an open-collector output.

Tr1, Tr2 = ON	Equivalent to low-level input
Tr1, Tr2 = OFF	Equivalent to high-level input

■ Selecting a Reference Pulse Form

Set the following parameter to indicate input pulse form.

Parameter	Name	Unit	Setting Range	Default Setting	Control Mode
P2-00	Input Pulse Form	-	1, 2	2	Position Control, Speed Control

Set reference pulse form input to the servo driver from the host controller.

Parameter	Setting	Input Pulse Form
P2-00	1	Quadrature Pulse Signal (multiplied 4)
	2	Sign & Pulse Signal

Diagram of “Quadrature Pulse Signal (multiplied 4)”

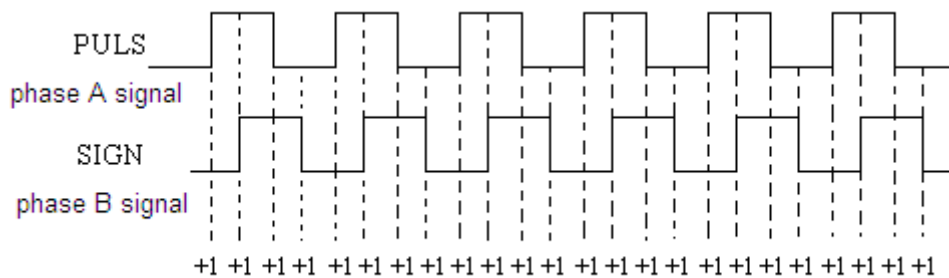

Reference Pulse Input Signal Timing

Reference Pulse Form	Electrical Specifications	Remarks
Sign+Pulse Input (SIGN+PULS Signal) Maximum reference frequency: Differential: 500kbps Open-collector: 200kbps	<p> $t1, t2 \leq 0.1\mu\text{s}$ $t3, t7 \leq 0.1\mu\text{s}$ $t4, t5, t6 > 3\mu\text{s}$ $\tau \geq 2.5\mu\text{s}$ $(\tau/T) \times 100 = 40\% \sim 60\%$ </p>	SIGN High=Forward reference Low=Reverse reference
Quadrature Pulse Signal Maximum reference frequency: Differential: 500kbps Open-collector: 200kbps	<p> $t1, t2 \leq 0.1\mu\text{s}$ $\tau \geq 2.5\mu\text{s}$ $(\tau/T) \times 100 = 40\% \sim 60\%$ </p>	A leads B ahead at 90°: Forward reference B leads A ahead at 90°: Reverse reference

■ Pulse Error Clear Input /CLR

The error clear signal /CLR clears the error counter of servo driver, and the position reference is set to current position.

■ Control Diagram

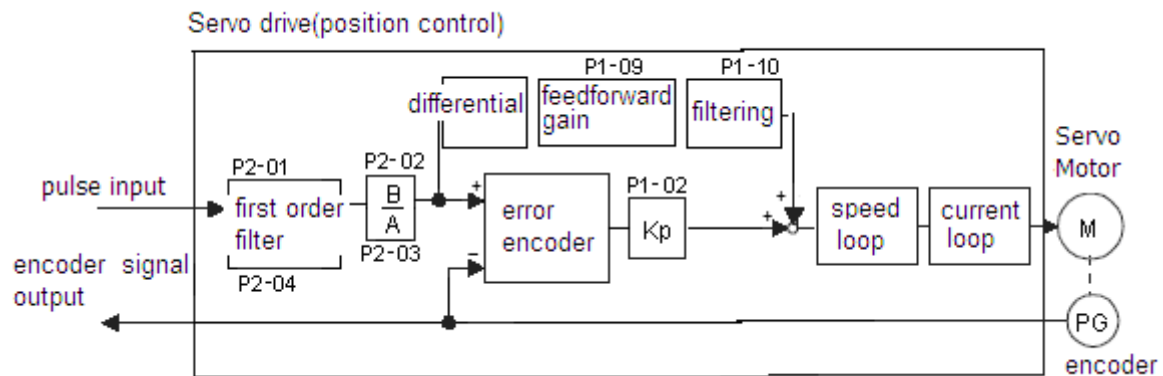

4-3-3. I/O Signals

I/O signals are used to control servo driver operation. Connect these signal terminals as required.

■ Input Signal Connections

Connect the input signals as shown below.

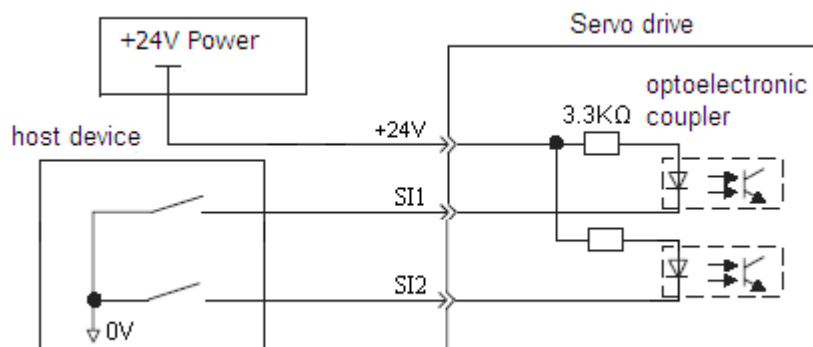

Note:

(1) Provide a separate external I/O power supply; the servo driver does not have an internal 24V power supply.

External power supply specifications: 24V \pm 1 VDC, 300mA minimum

(2) Recommend that using the same type of external power supply as that used for output circuits.

Signal Input	Description	Control Mode
+24V	+24V External power supply	Position Control, Speed Control and Torque Control

■ Output Signal Connections

Connect the output signals as shown in the following figure.

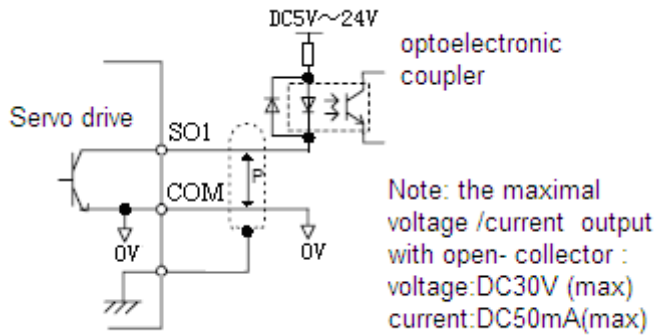
**Note:**

(1) Provide a separate external I/O power supply; the servo driver does not have an internal 24V power supply.

External power supply specifications: 24V \pm 1 VDC, 300mA minimum

(2) Recommend that using the same type of external power supply as that used for output circuits.

4-3-4. Electronic Gear

The electronic gear function enables the servomotor travel distance per input reference pulse to be set to any value. It allows the pulses generated by the host controller to be used for control without having to consider the equipment gear ratio or the number of encoder pulses.

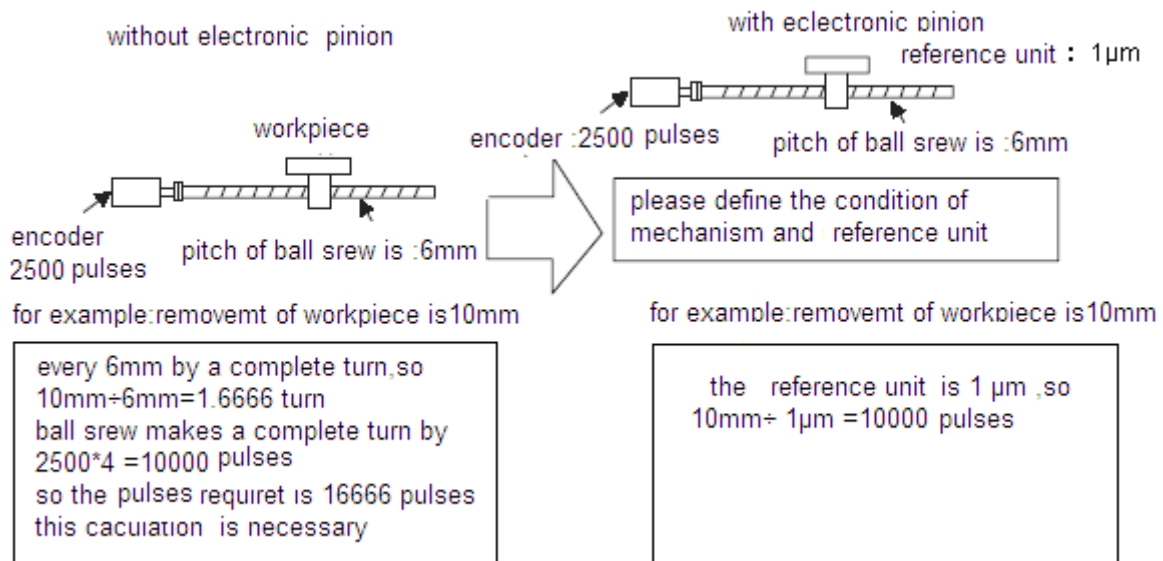
**■ Setting the Electronic Gear**

Calculate the electronic gear ratio (B/A) using the following procedure, and set the values in parameters P2-02 and P2-03.

1. Check equipment specifications related to the electronic gear:
 - Deceleration ratio
 - Ball screw pitch
 - Pulley diameter
2. Check the number of encoder pulses for the servomotor.
3. Determine the reference unit used.

A reference unit is the minimum position data unit used to move a load (Minimum

unit of reference from the host controller).



- Reference unit can be 0.1in or 0.01in or 0.01mm or 0.001mm, etc.
- A reference unit of one pulse moves the load by one reference unit.
- When the reference unit is 1 μ m, if a reference of 50000 units is input, the load moves 50mm (1.97in)(50000 \times 0.001mm = 50mm).

4. Determine the load travel distance per load shaft revolution in reference units.

Travel distance per load shaft revolution

= Travel distance per load shaft revolution / Reference Unit

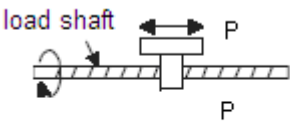
When the ball screw pitch is 0.20in (5mm) and the reference unit is 0.00004in (0.001mm), travel distance per load shaft revolution is 0.20/0.00004 = 5000(reference units).

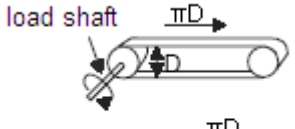
Ball Screw	Disc Table	Belt and Pulley
 <p>1 revolution = $\frac{P}{\text{reference unit}}$ note: p means pitch</p>	 <p>1 revolution = $\frac{360^\circ}{\text{reference unit}}$</p>	 <p>1 revolution = $\frac{\pi D}{\text{reference unit}}$ D: dia. of pulley</p>

5. Electronic gear ratio is given as: (B/A)

If the gear ratio of the motor and the load shaft is given as: (m/n)

where m is the rotation of the motor and n is the rotation of the load shaft,

$$\text{Electronic gear ratio} \left(\frac{B}{A} \right) = \frac{\text{pulses of encoder}}{\text{reference unit at every revolution}} \times \frac{m}{n}$$

Note: Make sure the electronic gear ratio satisfies the following condition:

$$0.01 \leq \text{Electronic Gear Ratio} \left(\frac{B}{A} \right) \leq 100$$

The servo driver will not work properly if the electronic gear ratio exceeds this range. In that case, modify either the load configuration or the reference unit.

6. Set the parameters.

Reduce the electronic gear ratio to the lower terms so that both A and B are integers smaller than 65535, then set A and B in the respective parameters:

$$\left(\frac{B}{A} \right) \begin{array}{l} \rightarrow \\ \rightarrow \end{array} \begin{array}{|c|c|} \hline \text{P2-02} & \text{Electronic Gear Ratio (Numerator)} \\ \hline \text{P2-03} & \text{Electronic Gear Ratio (Denominator)} \\ \hline \end{array}$$

Parameter	Name	Unit	Setting Range	Default Setting	Control Mode
P2-02	Electronic Gear Ratio (Numerator)	-	1~65535	1	Position Control
P2-03	Electronic Gear Ratio (Denominator)	-	1~65535	1	Position Control

■ Electronic Gear Setting Examples

The following examples show electronic gear settings for different load mechanisms.

(1) Ball Screws

reference unit : 0.001mm
load shaft

pitch of ball screw is :6mm
incremental encoder : 2500 pulses

the movement at every revolution of load shaft = $\frac{6\text{mm}}{0.01\text{mm}} = 6000$

Electronic Gear Ratio $\left(\frac{B}{A}\right) = \frac{2500 \times 4 \times 1}{6000 \times 1} = \frac{P2-02}{P2-03}$

Parameter	P2-02	10000
	P2-03	6000

(2) Circular Tables

reference unit: 0.1°
load shaft

reduction gear ratio : 3 : 1
incremental encoder: 2500 pulses

the movement at every revolution of load shaft = $\frac{360^\circ}{0.1^\circ} = 3600$

electronic gear ratio $\left(\frac{B}{A}\right) = \frac{2500 \times 4 \times 3}{3600 \times 1} = \frac{P2-02}{P2-03}$

Parameter	P2-02	30000
	P2-03	3600

(3) Belts and Pulleys

reference unit : 0.02mm
load shaft

reduction gear ratio : 2 : 1
dia. of pulley: φ100mm
incremental encoder: 2500 pulses

the movement at every revolution of load shaft = $\frac{3.14 \times 100\text{mm}}{0.02\text{mm}} = 15700$

electronic gear ratio $\left(\frac{B}{A}\right) = \frac{2500 \times 4 \times 2}{15700 \times 1} = \frac{P2-02}{P2-03}$

Parameter	P2-02	20000
	P2-03	15700

4-3-5. Digital Reference Speed Control

This function provides a method for easy speed control. It allows the user to initially set three different motor speeds with parameters, and then select one of the speeds externally using a input signal.

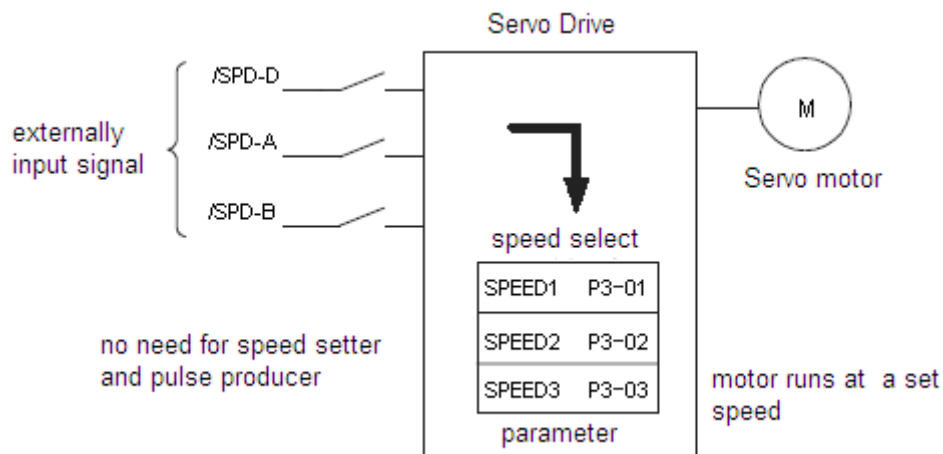

■ **Using Digital Reference Speed Control**

Follow steps 1 to 3 below to use digital reference speed control.

1. Set digital reference speed control as shown below.

Parameter	Name	Setting Range	Default Setting	Setting
P0-00	Main Mode	0	0	0
P0-01	Sub Mode 1	0~7	0	3: Speed (Digital Reference)
P0-02	Sub Mode 2	0~7	0	

Meanings for the following signals change when the digital reference speed control is used.

Sub Mode	Description	Input Signal			
		/SPD-D	/SPD-A	/SPD-B	Speed Reference
Speed (Digital Reference)	Using Digital Reference Speed Control	Direction 0: Forward 1: Reverse	0	0	0
			0	1	V-REF1 (P3-01)
		1	1	V-REF2 (P3-02)	
		1	0	V-REF3 (P3-03)	

Note: 0: OFF, 1: ON

2. Set the motor speeds with the following parameters.

Parameter	Name	Unit	Setting Range	Default Setting	Control Mode
P3-01	Speed 1 (V-REF1) Digital Reference Speed Control	rpm	-5000~+5000	100	Speed Control
P3-02	Speed 2 (V-REF2) Digital Reference Speed Control	rpm	-5000~+5000	200	Speed Control
P3-03	Speed 3 (V-REF3) Digital Reference Speed Control	rpm	-5000~+5000	300	Speed Control

If the setting is higher than the maximum motor speed of the servomotor, then the servomotor will rotate at its maximum speed.

Speed selection input signals /SPD-A and /SPD-B and the rotation direction selection signal /SPD-D enable the servomotor to run at the preset speeds.

3. Set the soft start time.

Parameter	Name	Unit	Setting Range	Default Setting	Control Mode
P3-05	Acceleration Time	ms	0~65535	0	Speed Control
P3-06	Deceleration Time	ms	0~65535	0	Speed Control

The servo driver internal speed reference controls speed by applying this acceleration and deceleration setting.

Smooth speed control can be performed by entering a progressive speed reference or using contact input speed control. Set each constant to 0 for normal speed control or position control.

Set each parameter to the following time intervals.

- P3-05: Time interval from when the servomotor accelerates from 0 to rated speed.
- P3-06: Time interval from when the servomotor decelerates from rated speed to 0.

The following example shows operation by digital reference speed control. Using the soft start function reduces physical shock when the speed is changing.

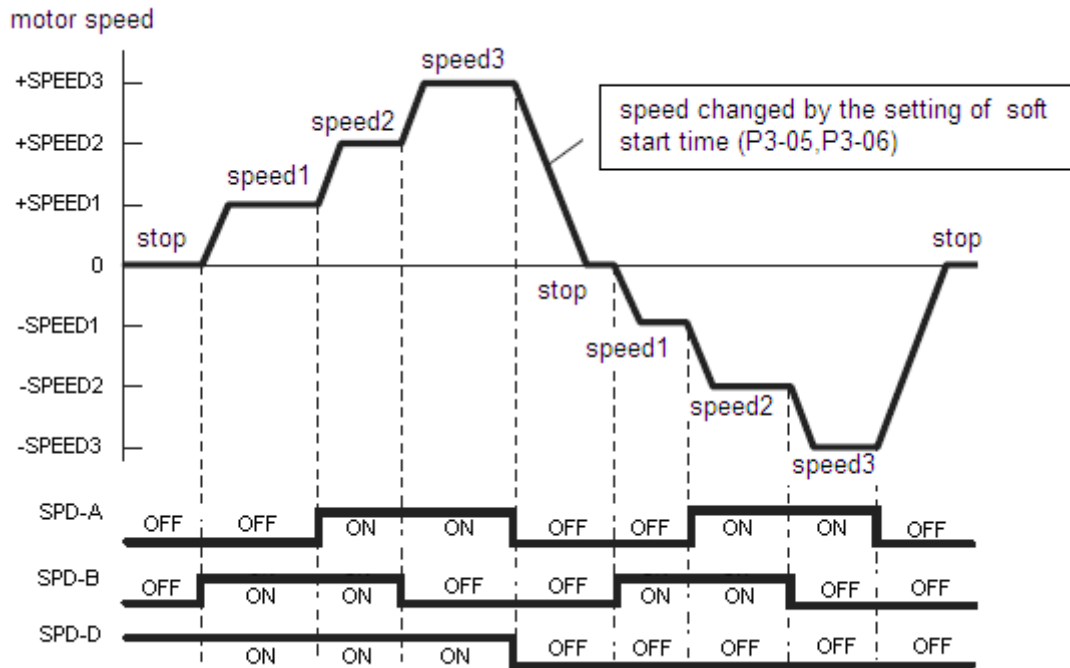

4-3-6. Torque Control

DS2 series servo driver can control torque in Torque(Digital Reference) Control Mode. Set the following parameter to select the torque(digital reference) control.

Parameter	Name	Setting Range	Default Setting	Setting
P0-00	Main Mode	0	0	0
P0-01	Sub Mode 1	0~7	0	1: Torque(Digital Reference)
P0-02	Sub Mode 2	0~7	0	

1. Control torque according to the digital reference.

Parameter	Name	Unit	Setting Range	Default Setting
P4-09	Torque Digital Reference	1%	-300~300	0

2. Speed limit during torque control.

Parameter	Name	Unit	Setting Range	Default Setting
P4-07	Speed Limit during Torque Control	rpm	0~5000	2000

4-3-7. Encoder Z Signal Output

Encoder Z signal can be output in DS2 series servo driver. Set the following parameter to enable the output function.

Parameter	Name	Unit	Setting Range	Default Setting
P5-38	Encoder Z Signal Assignment	-	n.0000~n.0012※1	n.0000

※1: Default setting of DS2-21P5 is “n.0013”.

Z signal outputs as a single pulse. The width of the pulse is about 1.5ms regardless of the speed of the motor.

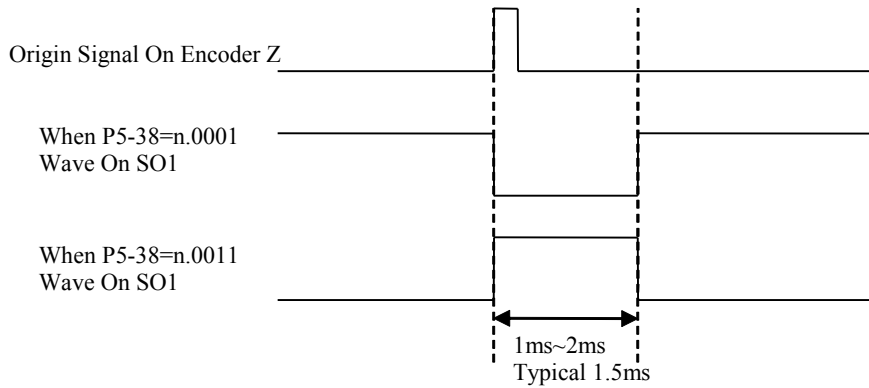

4-4. Setting Up the Servo Driver

This section describes the procedure for setting parameters to operate the DS series servo driver.

4-4-1. Indicating Control Mode

2 sub modes stand for 2 control modes, changing with input signal /C-SEL.

Sub mode 1 is selected when /C-SEL is OFF, whereas sub mode 2 is selected when /C-SEL is ON.

Input signal /C-SEL can be input from any input terminal by setting the following parameter.

Parameter	Name	Unit	Setting Range	Default Setting	Control Mode
P5-20	Control Mode Selection	-	n.0000~ n.0012 ※1	n.0000	Position Control, Speed Control and Torque Control

Default setting is n.0000 and is fixed to OFF.

Assign /C-SEL to any of the input terminals to enable change control mode function.

Please refer to 4-4-2(Input Signal Assignment) to know more about setting this parameter.

※1: Setting range of DS2-21P5 is “n.0000~n.0014”.

Set the following parameters to change the control mode.

Parameter	Name	Unit	Setting Range	Default Setting
P0-00	Main Mode	-	0	0
P0-01	Sub Mode 1	-	0~7	0
P0-02	Sub Mode 2	-	0~7	0

Main Mode	Sub Mode 1	Sub Mode 2
0: Normal	0: Idle	0: Idle
	1: Torque (Digital Reference)	1: Torque (Digital Reference)
	2: Torque (Analog Reference)	2: Torque (Analog Reference)
	3: Speed (Digital Reference)	3: Speed (Digital Reference)
	4: Speed (Analog Reference)	4: Speed (Analog Reference)
	5: Position (Digital Reference)	5: Position (Digital Reference)
	6: Position (Pulse Reference)	6: Position (Pulse Reference)
	7: Speed (Pulse Reference)	7: Speed (Pulse Reference)

Description of Control Modes

0: Idle

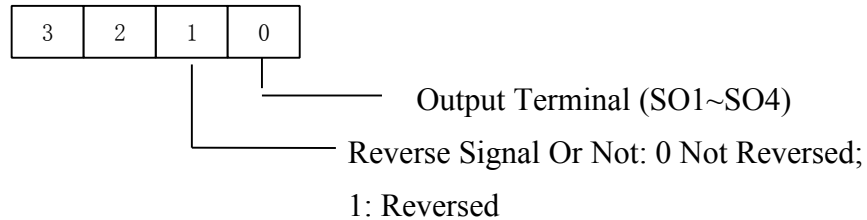
**Note:**

- (1) Signals are output with OR logic when multiple signals are assigned to the same output terminal(/Z is special).
- (2) When /Z signal is assigned to a terminal with other ordinary signals, /Z signal will take entire possession of that terminal, and other signals assigned to the same terminal cannot be output correctly.

4-4-4. Jog Speed

Use the following parameter to modify speed when operating the servomotor from the panel or by software.

Parameter	Name	Unit	Setting Range	Default Setting
P3-04	Jog Speed	rpm	0~1000	100

If the setting is higher than the maximum motor speed of the servomotor, then the servomotor will rotate at its maximum speed.

4-5. Setting Stop Functions

This section describes the procedure used to stop the servomotor properly.

4-5-1. Zero Clamp (/ZCLAMP)**■ Zero Clamp Function**

The zero clamp function is used for systems where the host controller does not form a position loop for the speed reference input. In other words, this function is used to stop and lock the servomotor even when the input voltage of speed reference is not 0. An internal position loop is temporarily formed to clamp the servomotor within one pulse when the zero clamp function is turned ON. Even if the servomotor is forcibly rotated by external force, it will still return to the zero clamp position.

■ Parameter Setting

Set the following parameter so that the input signal /ZCLAMP can be used to enable or disable the zero clamp function.

Parameter	Name	Unit	Setting Range	Default Setting	Control Mode
P5-21	Zero Clamp	-	n.0000~n.0012※1	n.0000	Speed Control

Default setting is n.0000 and is fixed to OFF.

Assign /ZClamp to any of the input terminals to enable Zero Clamp Function.

Please refer to 4-4-2(Input Signal Assignment) to know more about setting this parameter.

※1: Setting range of DS2-21P5 is “n.0000~n.0014”.

Zero clamp is performed when all the following conditions are satisfied:

- Speed control is selected (Sub Mode=3 or 4)
- /ZCLAMP=ON.
- Speed reference drops below the setting level of P5-01.

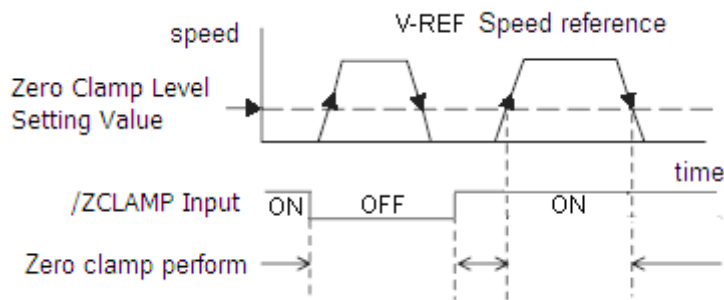

4-6. IO Signals Control

This section describes the procedure for using I/O signals of the servo driver.

4-6-1. Alarm Output (/ALM)

The basic procedure for connecting alarm output signals is described below.

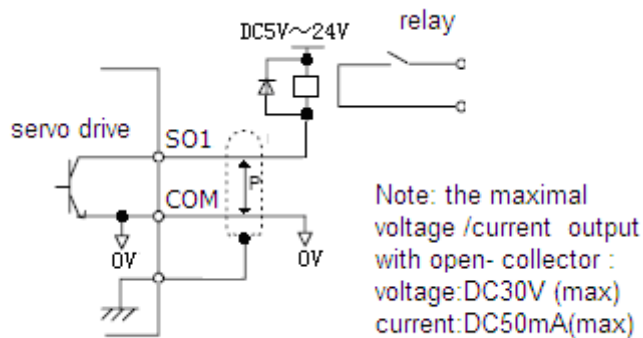

An external I/O power supply must be provided by the user separately because there is no internal 24V power supply in the servo driver.

Signal	Description	Control Mode
/ALM	Alarm Output	Position Control, Speed Control and Torque Control

/ALM is set to ON when a servo driver alarm is raised.

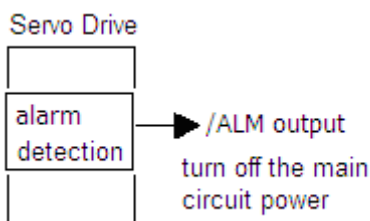

Form an external circuit so this alarm output (ALM) turns OFF the servo driver.

Signal	Signal Status	Reversed Or Not	Terminal Status	Description
/ALM	ON	Direct Output	On between SO and COM	Alarm State
		Reverse Output	Off between SO and COM	
/ALM	OFF	Direct Output	On between SO and COM	Normal State
		Reverse Output	Off between SO and COM	

Set the following parameter so that the output signal /ALM can be used to output to any output terminal.

Parameter	Name	Unit	Setting Range	Default Setting
P5-37	Alarm Signal Assignment	-	n.0000~n.0012※1	n.0002

Default setting is n.0002 and is output between SO2 and COM.

Please refer to 4-4-3(Output Signal Assignment) to know more about setting this parameter.

※1: Setting range of DS2-21P5 is “n.0000~n.0013”.

When a servo alarm (/ALM) raised, eliminate the cause of the alarm and set the /ALM-RST input signal to ON to reset the alarm.

Signal	Description	Control Mode
/ALM-RST	Alarm Reset	Position Control, Speed Control and Torque Control

The alarm reset signal is used to reset a servo alarm.

Alarms can also be reset using a panel or digital operator.

4-6-2. Servo ON Input (S-ON)

There are two method to input Servo On signal, 1, input from a terminal, 2, automatically servo on after power on.

■ Input From Terminal

The basic use and wiring procedure for the Servo ON (/S-ON) input signal is described below. Use this signal to forcibly turn OFF the servomotor from the host controller.

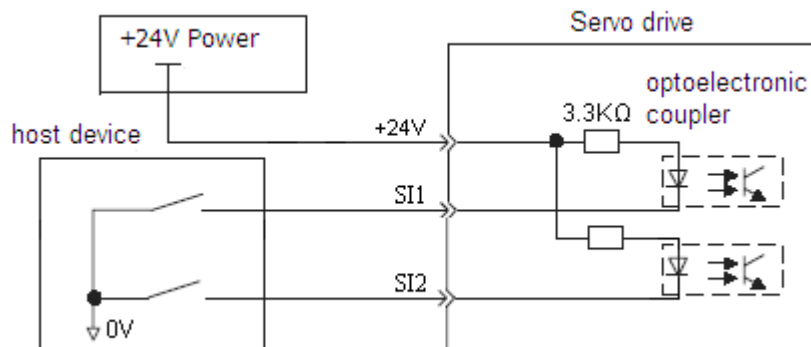

Signal	Description	Control Mode
/S-ON	Servo On	Position Control, Speed Control and Torque Control

Do not use the Servo ON (/S-ON) signal to start or stop the motor. Always use an input reference signal to start or stop the servomotor.

■ Automatically Servo On After Power On(Not Use /S-ON Signal)

Set the parameter P5-10 to n.0010 to make servo driver automatically servo on after power on. Please refer to 4-1-6.

4-6-3. Positioning Completed Output (/COIN)

The basic use and wiring procedure for the positioning completed (/COIN) output Signal is described below. This signal is output to indicate that servomotor positioning is completed.

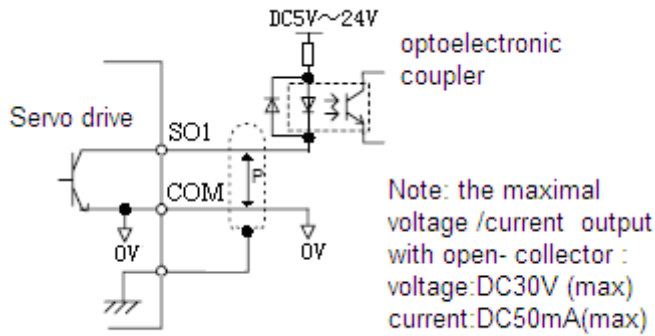

Signal	Description	Control Mode
/COIN	Positioning Completed	Position Control

This signal indicates that servomotor movement has completed a positioning. The host controller uses the signal as an interlock to confirm that positioning is completed.

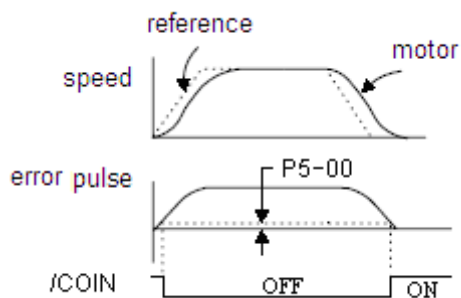

Signal	Signal Status	Reversed Or Not	Terminal Status	Description
/COIN	ON	Direct Output	On between SO and COM	Positioning Completed
		Reverse Output	Off between SO and COM	
	OFF	Direct Output	On between SO and COM	In Positioning
		Reverse Output	Off between SO and COM	

Set the following parameter so that the output signal /COIN can be used to output to any output terminal.

Parameter	Name	Unit	Setting Range	Default Setting
P5-28	/COIN Signal Assignment	-	n.0000~n.0012 ※1	n.0001

Default setting is n.0001 and is output between SO1 and COM.

Please refer to 4-4-3(Output Signal Assignment) to know more about setting this parameter.

※1: Setting range of DS2-21P5 is “n.0000~n.0013”.

The following parameter is used to set the number of error pulses and to adjust the output width of the positioning completed signal.

Parameter	Name	Unit	Setting Range	Default Setting	Control Mode
P5-00	Positioning Completed Width	ref unit	0~250	7	Position Control

When in position control mode and the error between position reference and actual position drops below the level indicated by P5-00, output signal /COIN is turned to ON, which means the positioning is completed. Default setting of P5-00 is 7 ref units. /COIN is fixed to OFF in speed control and torque control.

4-6-4. Speed Coincidence Output (/V-CMP)

The basic use and wiring procedures for the speed coincidence (/V-CMP) output signal, used to indicate a match with the speed reference, are described below. The host controller uses the signal as an interlock.

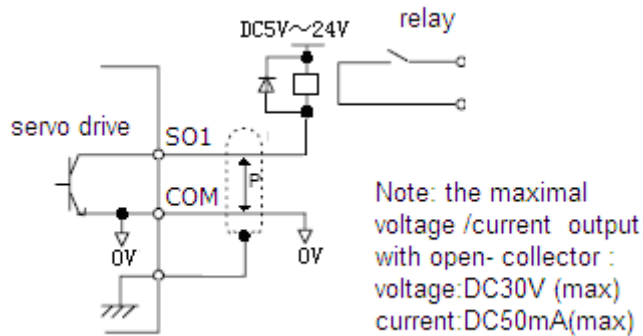

Signal	Description	Control Mode
/V-CMP	Speed Coincidence Output	Speed Control

Signal	Signal Status	Reversed Or Not	Terminal Status	Description
/V-CMP	ON	Direct Output	On between SO and COM	Speed coincides
		Reverse Output	Off between SO and COM	
	OFF	Direct Output	On between SO and COM	Speed does not coincide
		Reverse Output	Off between SO and COM	

Set the following parameter so that the output signal /V-CMP can be used to output to any output terminal.

Parameter	Name	Unit	Setting Range	Default Setting
P5-29	/V-CMP Signal Assignment	-	n.0000~n.0012※1	n.0000

Default setting is n.0000 and is not output to terminal.

Please refer to 4-4-3(Output Signal Assignment) to know more about setting this parameter.

※1: Setting range of DS2-21P5 is “n.0000~n.0013”.

The following parameter is used to set the number of error pulses and to adjust the output width of the speed coincidence signal.

Parameter	Name	Unit	Setting Range	Default Setting
P5-03	Speed Coincidence Signal Output Width	rpm	1~250	10

When in speed control and the error between speed reference and speed feedback drops below the level indicated by P5-03, output signal /V-CMP is turned to ON, which means the current speed matches the speed reference.

4-6-5. Rotation Detection Output (/TGON)

The basic use and wiring procedures for the Rotation Detection (/TGON) output signal are described below. The signal can be activated to indicate that the servomotor is currently operating. It is used as an external interlock.

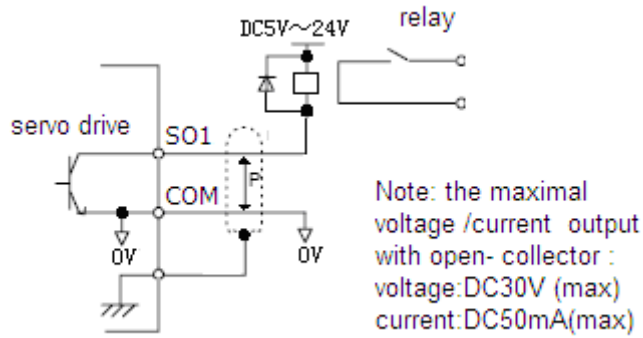

Signal	Description	Control Mode
/TGON	Rotation Detection Output	Position Control, Speed Control and Torque Control

Signal	Signal Status	Reversed Or Not	Terminal Status	Description
/TGON	ON	Direct Output	On between SO and COM	Motor is operating
		Reverse Output	Off between SO and COM	
/TGON	OFF	Direct Output	On between SO and COM	Motor is not operating
		Reverse Output	Off between SO and COM	

Parameter: P5-02 (Rotation Detection Speed Level)

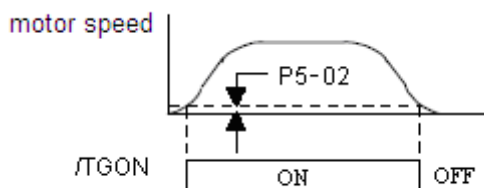

Set the following parameter so that the output signal /TGON can be used to output to any output terminal.

Parameter	Name	Unit	Setting Range	Default Setting
P5-30	/TGON Signal Assignment	-	n.0000~n.0012※1	n.0000

Default setting is n.0000 and is not output to terminal.

Please refer to 4-4-3(Output Signal Assignment) to know more about setting this parameter.

※1: Setting range of DS2-21P5 is “n.0000~n.0013”.

The following parameter is used to set the number of error pulses and to adjust the output width of the rotation detection signal.

Parameter	Name	Unit	Setting Range	Default Setting
P5-02	Rotation Detection Speed Level	rpm	1~1000	20

If speed exceeds the level indicated by P5-02, /TGON signal is turned to ON, which means the motor is rotating.

4-6-6. Servo Ready Output (/S-RDY)

The basic use and wiring procedures for the Servo Ready (/S-RDY) output signal are described below

Servo Ready means there are no servo alarms and the main circuit power supply is turned ON.

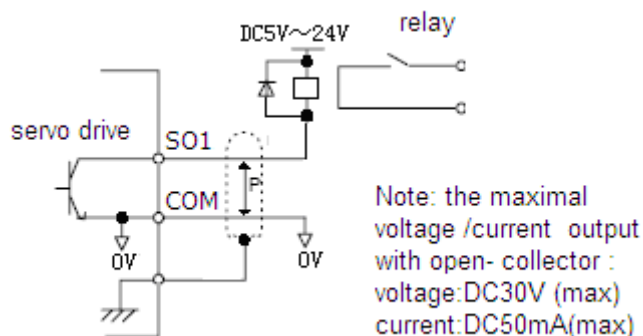

Signal	Description	Control Mode
/S-RDY	Servo Ready Output	Position Control, Speed Control and Torque Control

This signal indicates that the servo driver has completed all preparations and is ready to receive the Servo ON signal.

Signal	Signal Status	Reversed Or Not	Terminal Status	Description
/S-RDY	ON	Direct Output	On between SO and COM	Servo is ready
		Reverse Output	Off between SO and COM	
	OFF	Direct Output	On between SO and COM	Servo is not ready
		Reverse Output	Off between SO and COM	

Set the following parameter so that the output signal /TGON can be used to output to any output terminal.

Parameter	Name	Unit	Setting Range	Default Setting
P5-31	/S-RDY Signal Assignment	-	n.0000~n.0012※1	n.0000

For DS2-20P4 and DS2-20P7, default setting is n.0000 and is not output to terminal.

For DS2-21P5, default setting is n.0003 and is output between SO3 and COM.

Please refer to 4-4-3(Output Signal Assignment) to know more about setting this parameter.

※1: Setting range of DS2-21P5 is “n.0000~n.0013”.

4-6-7. Near Output (/NEAR)

The basic use and wiring procedures for the near (/NEAR) output signal are described below. The signal is generally output together with the positioning completed signal (/COIN), and it is used to indicate the servomotor is close to completing positioning.

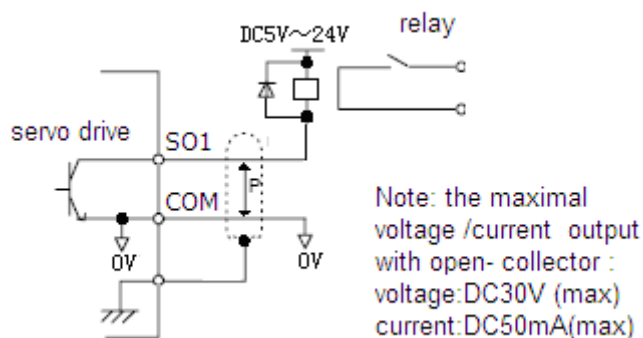

Signal	Description	Control Mode
/NEAR	Near Output	Position Control

The host controller can use the /NEAR signal to prepare the next motion sequence before

receiving the positioning completed signal. This reduces the time required to complete the desired motion profile.

Signal	Signal Status	Reversed Or Not	Terminal Status	Description
/NEAR	ON	Direct Output	On between SO and COM	Near to the position reference
		Reverse Output	Off between SO and COM	
	OFF	Direct Output	On between SO and COM	Not near to the position reference
		Reverse Output	Off between SO and COM	

Set the following parameter so that the output signal /NEAR can be used to output to any output terminal.

Parameter	Name	Unit	Setting Range	Default Setting
P5-36	/NEAR Signal Assignment	-	n.0000~n.0012※1	n.0000

Default setting is n.0000 and is not output to terminal.

Please refer to 4-4-3(Output Signal Assignment) to know more about setting this parameter.

※1: Setting range of DS2-21P5 is “n.0000~n.0013”.

The following parameter is used to set the number of error pulses and to adjust the output width of the positioning nearing signal.

Parameter	Name	Unit	Setting Range	Default Setting
P5-04	Positioning Nearing Signal Width	ref unit	0~10000	50

Generally set the near signal width higher than the positioning completed width. Please refer to 4-6-3 “Positioning Completed Output (/COIN)”.

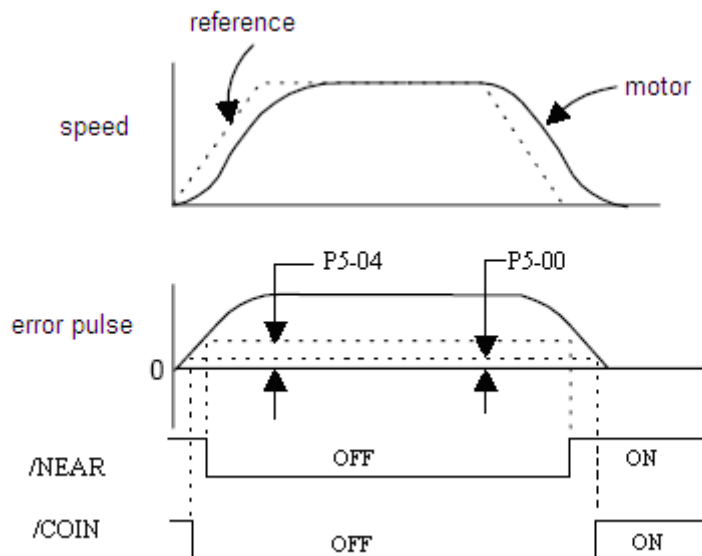

4-6-8. Warning Output (WARN)

The basic use and wiring procedure for the warning (/WARN) output signal are given below.

When the servomotor is overloading, /WARN signal is turned to ON. If it is still overloading for a definite time, alarm is raised and /ALARM signal is turned to ON.

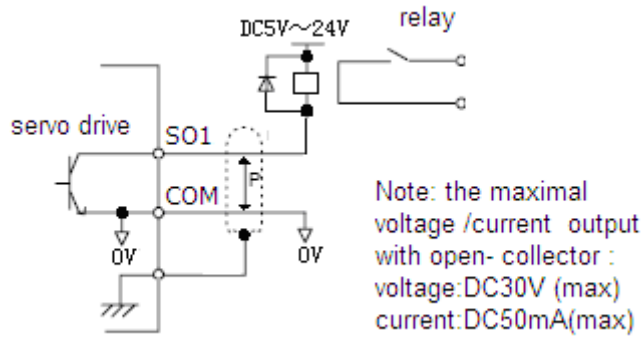

Signal	Description	Control Mode
/WARN	Warning Output	Position Control, Speed Control and Torque Control

Signal	Signal Status	Reversed Or Not	Terminal Status	Description
/WARN	ON	Direct Output	On between SO and COM	Warning
		Reverse Output	Off between SO and COM	
	OFF	Direct Output	On between SO and COM	Normal
		Reverse Output	Off between SO and COM	

Set the following parameter so that the output signal /WARN can be used to output to any output terminal.

Parameter	Name	Unit	Setting Range	Default Setting
P5-35	/WARN Signal Assignment	-	n.0000~n.0012※1	n.0000

Default setting is n.0000 and is not output to terminal.

Please refer to 4-4-3(Output Signal Assignment) to know more about setting this parameter.

※1: Setting range of DS2-21P5 is “n.0000~n.0013”.

4-7. Smooth Operation

This section provides technical information on the smooth operation of servomotors.

4-7-1. Smoothing

The smoothing function applies a filter inside the servo driver to a constant-frequency reference input so that acceleration and deceleration can be as constant as possible. To use this function, set the following parameters.

Use the following parameter to set the type of filter to be applied.

Parameter	Name	Unit	Setting Range	Default Setting	Control Mode
P2-01	Position Reference Filter Type	-	0, 1	0	Position Control

Either an acceleration/deceleration or average movement filter can be selected.

Setting	Description
0	Enables acceleration/deceleration filter.
1	Enables average movement filter.

The time constant and time for these filters are set in the following parameters.

Parameter	Name	Unit	Setting Range	Default Setting	Control Mode
P2-04	Position Reference Filter Time Contant	ms	0~100	0	Position Control

Position reference filter is effective to both position control(Pulse Reference) and speed control(Pulse Reference).

4-7-2. Soft Start Function

The soft start function adjusts progressive speed reference input inside the servo driver so that acceleration and deceleration can be as constant as possible. To use this function, set the following parameters.

Parameter	Name	Unit	Setting Range	Default Setting	Control Mode
P3-05	Acceleration Time	ms	0~65535	0	Speed Control
P3-06	Deceleration Time	ms	0~65535	0	Speed Control

In the servo driver, a speed reference is re-calculated by the acceleration or deceleration value set in P3-05 or P3-06 to provide speed control.

The soft start function enables smooth speed control when progressive speed references are input or when Digital Reference Speed Control is used. Set both P3-05 and P3-06 to "0" for normal speed control.

Set these parameters as follows:

- P3-05: Time interval from when the servomotor accelerates from 0 to rated speed.
- P3-06: Time interval from when the servomotor decelerates from rated speed to 0.

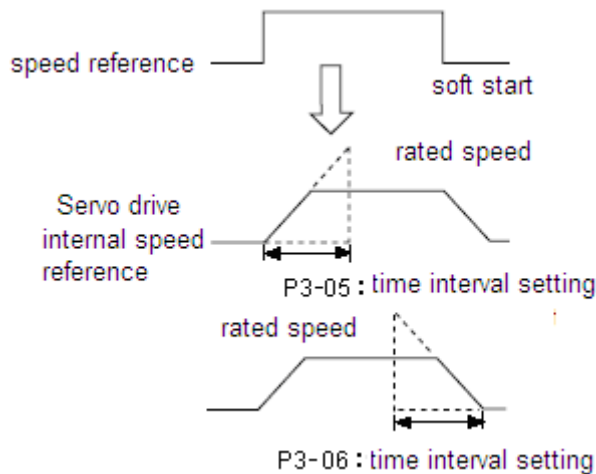

4-8. Gain Adjustments

This section describes information on the basic rules of gain adjustments in the servo driver, adjustment methods in a variety of cases, and reference set values.

4-8-1. Servo Gain Parameters

■ Setting Speed Loop Gain

Set the following speed loop related parameters as required.

Parameter	Name	Unit	Setting Range	Default Setting	Control Mode
P1-00	Speed Loop Gain	Hz	1~500	100	Position Control, Speed Control
P1-01	Speed Loop Integral Time Constant	0.1ms	1~5000	400	Position Control, Speed Control

The higher the speed loop gain, or the smaller the speed loop integral time constant value, the faster the speed control response will be. There is, however, a certain limit depending on machine characteristics.

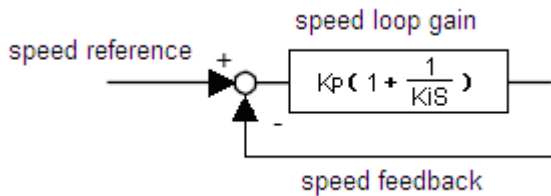

■ Setting Position Loop Gain

Set the following position loop-related parameter as required.

Parameter	Name	Unit	Setting Range	Default Setting	Control Mode
P1-02	Position Loop Gain	1/s	1~2000	30	Position Control

The higher the position loop gain, the smaller the position control error will be. There is, however, a certain limit depending on machine characteristics.

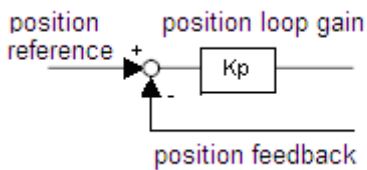

This gain setting is also valid for zero clamp operation.

Set in this parameter the error pulse level at which a position error pulse overflow alarm is raised.

Parameter	Name	Unit	Setting Range	Default Setting	Control Mode
P5-05	Position Error Overflow Level	256 ref units	0~65535	1000	Speed Control

When Position Error Overflow Level is set to 0, the alarm is never raised.

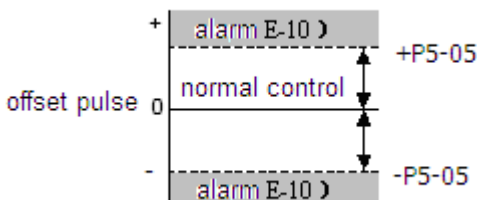

If the machine permits only a small position loop gain value to be set in P1-02, an overflow alarm may arise during high speed operation. In this case, increase the value set in this parameter to avoid unnecessary alarms.

4-8-2. Using Proportional Control (/P-CON)

Input signal /P-CON serves as a PI/P control changeover switch.

PI control: Proportional/integral control.

P control: Proportional control.

■ Methods for Using Proportional Control

Set the following parameter so that the input signal /P-CON can be used to proportional control.

Parameter	Name	Unit	Setting Range	Default Setting	Control Mode
P5-11	/P-CON Signal Assignment	-	n.0000~n.0012 ※1	n.0000	Position Control, Speed Control

Default setting is n.0000 and is fixed to OFF.

Assign /P-CON to any of the input terminals to use proportional control.
Please refer to 4-4-2(Input Signal Assignment) to know more about setting this parameter.

Proportional control can be used in the following two ways.

- 1, When operation is performed by sending speed references from the host controller to the servo driver, the host controller can selectively use P control mode for particular conditions only. This method can suppress overshooting and shorten setting time.
- 2, If PI control mode is used when the speed reference has a reference offset, the motor may rotate at a very slow speed and fail to stop even if 0 is specified as a speed reference. In this case, use P control mode to stop the motor.

4-8-3. Gain Selection (/G-SEL)

Gain selection is a function that can switch gain during the motor is running.
For example, if gain needs to be changed when motor is stopped, set different gain group and use a external signal to select the group of gain.

Set the following parameter so that the input signal /G-SEL can be used to select gain.

Parameter	Name	Unit	Setting Range	Default Setting	Control Mode
P5-23	/G-SEL Signal Assignment	-	n.0000~n.0012※1	n.0000	Position Control, Speed Control

Default setting is n.0000 and is fixed to OFF.

Assign /G-SEL to any of the input terminals to select gain.

Please refer to 4-4-2(Input Signal Assignment) to know more about setting this parameter.

The first group of gain is selected when /G-SEL is OFF, and the second group of gain is selected when /G-SEL is ON.

/G-SEL Signal	OFF	ON
Speed Loop Gain	P1-00 is selected.	P1-04 is selected.
Speed Loop Integral Time Contant	P1-01 is selected.	P1-05 is selected.
Position Loop Gain	P1-02 is selected.	P1-06 is selected.

5 Using Digital Panel

This chapter describes the basic operation of the digital panel and the features it offers. All parameter settings and motor operations can be executed by simple, convenient operations. Operate the digital panel as you read through this chapter.

5-1. Basic Operation

This section provides information on the basic operation of the digital panel for setting operating conditions.

5-1-1. Functions Of Digital Panel

The digital panel can be used for parameter settings, operating references, and status displays.

- 5 7Seg-LEDs: Displaying parameter settings, status or alarm.
- Power LED POWER: The LED is on when the servo driver is powered on.
- Charge LED CHARGE: The LED is on when the main circuit is powered on. When the power of main circuit is off, electric charge still remains in the capacitors, and at this time DO NOT touch servo driver.

This section provides information on the keys and their functions available from the initial displays.

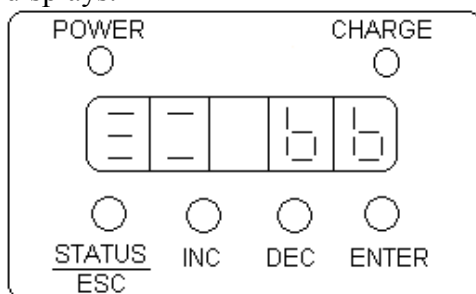

Key Name	Function
STATUS/ESC	Press: Status switch, status return
INC	Press: Increase the value; Press and hold: Increase the value continuously
DEC	Press: Decrease the value; Press and hold: Decrease the value continuously
ENTER	Press: Shift the editing digit; Press and hold: Enter a status, Enter

5-1-2. Basic Mode Selection

The basic mode selection of the digital panel is used for indicating the status of the servo driver in operation and setting a variety of parameters and operation references.

The status display, auxiliary function, parameter setting, and monitor modes are the basic modes. As shown below, the mode is selected in the following order by pressing the key.

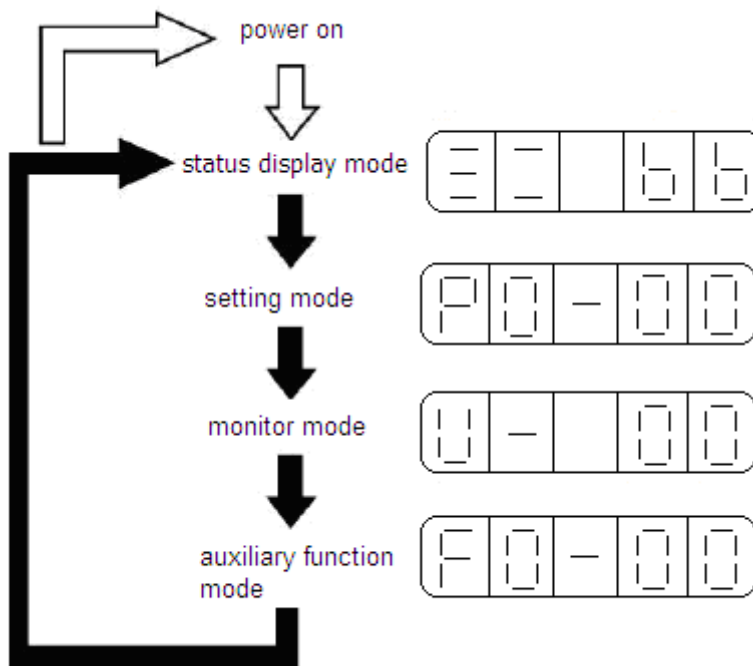

Display mode:

- Monitor Function U— XX: XX means the number of the monitor function.
- Auxiliary Function FX— XX: The first X means group No., the last two XX means the member No. in the group.
- Parameter Setting PX— XX: The first X means group No., the last two XX means the member No. in the group.
- Alarm E— XXX: XXX means the alarm code.

5-2. Status Display Mode

In status display mode, bit data and codes are displayed to indicate the status of the servo driver.

■ Selecting Status Display Mode

The digital operator goes into status display mode when the digital operation is turned ON.

■ Data in Status Display Mode

The screen contents in status display are different for speed, torque, and position control modes.

➤ Speed and Torque Control Mode

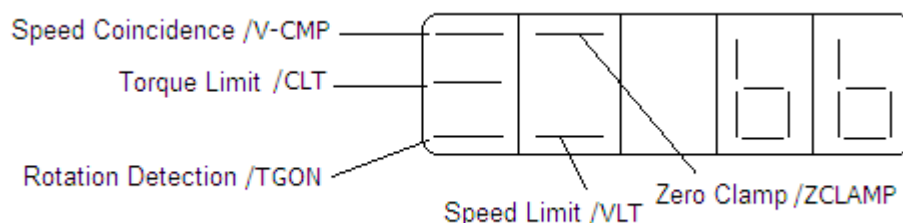

A. The following tables list and explain the meanings of bit data displays in Speed, and Torque Control Modes.

Bit Data	Description
Speed Coincidence (/V-CMP)	Lit when the difference between the motor speed and reference speed is the same as or less than the value set in P5-03.
Torque Limit (/CLT)	Lit if actual torque exceeds preset value.

	Forward Torque Limit: P4-02 Reverse Torque Limit: P4-03
Rotation Detection (/TGON)	Lit if speed exceeds the level indicated by P5-02. Rotation Detection Speed Level: P5-02(Unit: rpm)
Zero Clamp (/ZCLAMP)	Lit if /ZCLAMP signal is ON.
Speed Limit (/VLT)	Lit if actual speed exceeds preset value. Speed Limit during Torque Control: P4-07

B. The following tables list and explain the meanings of code displays in Speed, and Torque Control Modes.

Code	Description
	Standby Servo OFF (motor power OFF)
	Run Servo ON (motor power ON)
	Forward Run Prohibited P-OT is OFF. Please refer to 4-2-2 “Overtravel Limit”
	Reverse Run Prohibited N-OT is OFF. Please refer to 4-2-2 “Overtravel Limit”

➤ Position Control Mode

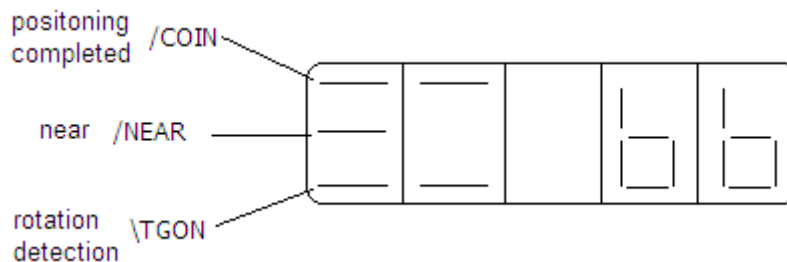

A. The following tables list and explain the meanings of bit data displays in Speed, and Torque Control Modes.

Bit Data	Description
Positioning Completed (/COIN)	Lit if error between position reference and actual motor position is below the value set in P5-00.
Near (/NEAR)	Lit if error between position reference and actual motor position is below the value set in P5-04.
Rotation Detection (/TGON)	Lit if speed exceeds the level indicated by P5-02. Rotation Detection Speed Level: P5-02(Unit: rpm)

B. The following tables list and explain the meanings of code displays in Speed, and Torque Control Modes.

Code	Description
	Standby Servo OFF (motor power OFF)
	Run Servo ON (motor power ON)
	Forward Run Prohibited P-OT is OFF. Please refer to 4-2-2 “Overtravel

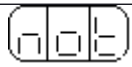
	Limit”
	Reverse Run Prohibited N-OT is OFF. Please refer to 4-2-2 “Overtravel Limit”

5-3. Monitor Mode

The Monitor Mode can be used for monitoring the reference values, I/O signal status, and servo driver internal status.

The monitor mode can be set during motor operation.

■ Using the Monitor Mode

The example below shows how to display 0, the contents of monitor number U-16.

1. Press the STATUS/ESC key to select the monitor mode.

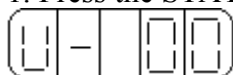

2. Press the INC or DEC key to select the monitor number U-16, and then press and hold ENTER to enter the monitor mode..

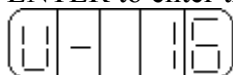

3. The value 0 is now displayed.



This completes the example procedure for displaying 0, the contents of monitor number U-16.

4. Press STATUS/ESC key to return to the monitor number display

■ Contents of Monitor Mode Display

Number	Monitor Display	Unit
U-00	Actual speed	rpm
U-01	Speed reference	rpm
U-02	Internal torque reference	%
U-03	Rotate angle (mechenism angle)	0.1°
U-04	Rotate angle (electrical angle)	0.1°
U-05	DC voltage	V
U-06	Module temperature	0.1℃
U-07	Input reference pulse speed	rpm
U-08	Pulse error	(0000~9999)*1
U-09		(0000~9999)*9999
U-10	Rotate angle (encoder pulse)	(0000~9999)*1
U-11		(0000~9999)*9999
U-12	Input reference pulse counter	(0000~9999)*1
U-13		(0000~9999)*9999
U-14	Feedback reference pulse counter	(0000~9999)*1
U-15		(0000~9999)*9999
U-16	Current position (Accumulated)	(0000~9999)*1
U-17		(0000~9999)*9999
U-18	Current	0.1A
U-19	Analog input V-REF	0.01V
U-20	Analog input T-REF	0.01V
U-21	I/O signals status	
U-22	I/O terminals status	

■ U-21 displays I/O signals status

The following diagram describes the input and output signals status displayed in U-21.

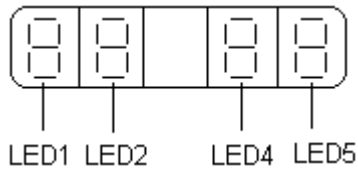

Diagram 1

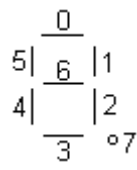

Diagram 2

In diagram 1, LED4 and LED5 stand for input signals status, and LED1 and LED2 stand for output signals status. In diagram 2 there shows the segment No. of each LED.

➤ Input signals status

Segment	Description	Segment	Description
LED4_0	/SPD-A	LED5_0	/S-ON
LED4_1	/SPD-B	LED5_1	/P-CON
LED4_2	/C-SEL	LED5_2	/P-OT
LED4_3	/ZCLAMP	LED5_3	/N-OT
LED4_4	/INHIBIT	LED5_4	/ALM-RST
LED4_5	/G-SEL	LED5_5	/P-CL
LED4_6	/CLR	LED5_6	/N-CL
		LED5_7	/SPD-D

➤ Output signals status

Segment	Description	Segment	Description
LED1_0	/NEAR	LED2_0	/COIN
LED1_1	/ALM	LED2_1	/V-CMP
LED1_2	/Z	LED2_2	/TGON
		LED2_3	/S-RDY
		LED2_4	/CLT
		LED2_5	/VLT
		LED2_6	/BK
		LED2_7	/WARN

■ U-22 displays I/O terminals status.

The following diagram describes the input and output terminals status displayed in U-22.

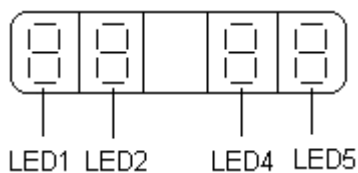

Diagram 1

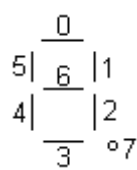

Diagram 2

In diagram 1, LED5 stands for input signals status, and LED2 stands for output signals status. In diagram 2 there shows the segment No. of each LED.

Input terminals		Output terminals	
Segment	Description	Segment	Description
LED5_0	Input status on SI1	LED2_0	Output status on SO1
LED5_1	Input status on SI2	LED2_1	Output status on SO2
LED5_2	Input status on SI3	LED2_2	Output status on SO3
LED5_3	Input status on SI4		

5-4. Auxiliary Function

This section describes how to apply the basic operations using the digital panel to run and adjust the servo driver.

Group No.	Description
F0-**	Checking system information
F1-**	Auxiliary run mode
F2-00	Setting motor code
F3-**	Checking alarm information
F4-00	Reset parameters to default
F5-00	External communication

5-4-1. Check System Information

Press the STATUS/ESC key to select the auxiliary function mode. Set the group No. to 0 to check system information. Press INC or DEC key to select different member No., and press and hold ENTER key to check current information. Press STATUS/ESC key to return.

The following table describes the meaning of each member No.

Member No.	Description	Member No.	Description
F0-00	Motor Code	F0-01	Servo Series
F0-02	Servo Model	F0-03	Prod Date: Year
F0-04	Prod Date: Month	F0-05	Prod Date: Day
F0-06	Software Version	F0-07	Hardware Version

5-4-2. Auxiliary Run Mode

Press the STATUS/ESC key to select the auxiliary function mode. Set the group No. to 1 to auxiliary run mode. Press INC or DEC key to select different member No., and press and hold ENTER key to use current function. Press STATUS/ESC key to return.

1. Jog (F1-00)

Make sure that the motor shaft is detached from machine before jogging!

Press ENTER key to power on the motor (servo on). After doing this, press and hold INC key for forward jogging, or DEC key for reverse jogging. Press STATUS/ESC key to power off the motor (servo off), and press STATUS/ESC key again to return.

4 different states are displayed in jogging.

State	Panel Display	State	Panel Display
Idle		Forward Jogging	
Servo ON		Reverse Jogging	

2. Trial Operation (F1-01)

Make sure that the motor shaft is detached from machine before trial operation!

When servo driver is connected with non-oriented encoder line or power line, trial operation must be run first to ensure that the encoder line or power line is connected exactly correct.

Set the display value to 1, and press and hold ENTER key to enter trial operation mode.

There the panle displays:



If correctly wired, the motor would rotate in 5 seconds in forward direction (fixed to counter-clockwise), otherwise the motor would shock or vibrate, raising an alarm for worse. In this case the power must be switched off immediately and check the wiring again.

Press STATUS/ESC key to return.

3. Current Offset Auto-Adjustment (F1-02)

After the servo driver is updated to latest software version, or the motor does not revolve smoothly after a long time run, a current offset auto-adjustment is recommended.

Select F1-02 and enter current offset auto-adjustment function, and the panel displays “rEF” .

Press ENTER key to start current offset auto-adjustment, and the panel displays blinking “rEF”.

About 5 seconds later auto-adjustment is finished, and the panel displays “donE” to inform that the function is already executed out.

Press STATUS/ESC key to return.

4. Speed Reference Auto-Adjustment (F1-03)

Select F1-03 and enter speed reference auto-adjustment function, and the panel displays “rEF_o” .

Press ENTER key to start speed reference auto-adjustment, and the panel displays blinking “rEF_o”.

About 1 second later auto-adjustment is finished, and the panel displays “donE” to inform that the function is already executed out.

Press STATUS/ESC key to return.

5. Torque Reference Auto-Adjustment (F1-04)

Select F1-04 and enter torque reference auto-adjustment function, and the panel displays “rEF_o” .

Press ENTER key to start torque reference auto-adjustment, and the panel displays blinking “rEF_o”.

About 1 second later auto-adjustment is finished, and the panel displays “donE” to inform that the function is already executed out.

Press STATUS/ESC key to return.

6. Force Servo On (F1-05)

0: Force servo on function is disabled.

1: Force servo on function is enabled.

5-4-3. Set Motor Code

Set group No. to 2 in auxiliary function and enter setting motor code function.

One servo drive can be suitable to more than one servo motor with close power classes printed on the nameplate of each motor. When user need to change a motor, please refer to the Quick Guide to ensure the needed motor is supported by the driver.

The following steps show how to set motor code.

1. Press STATUS/ESC key to select Auxiliary Function.
2. Press INC or DEC key to set group No. to 2, and press ENTER key.
3. Press and hold ENTER key to display current motor code.
4. Press INC, DEC or ENTER key to modify the value displayed on the panel to select the needed motor code and press and hold ENTER key to confirm.
5. Restart servo driver to make this function effective.

5-4-4. Check Alarm Information

Set group No. to 2 in auxiliary function and enter checking alarm information function. The following steps show how to check alarm information.

1. Press STATUS/ESC key to select Auxiliary Function.
2. Press INC or DEC key to set group No. to 3, and press ENTER key.
3. Press INC, DEC or ENTER key to modify the value displayed on the panel to select the member No..
4. Press and hold ENTER key to display corresponding alarm information..

Member No.	Description	Unit
F3-00	Current alarm code ※1	
F3-01	Current warn code ※2	
F3-02	Alarm/warn code 1 when alarm raised	
F3-03	U phase current when alarm raised	A
F3-04	V phase current when alarm raised	A
F3-05	DC voltage when alarm raised	V
F3-06	IGBT temperature when alarm raised	°C
F3-07	Speed when alarm raised	rpm
F3-08	Internal torque reference when alarm raised	%
F3-09	V-REF when alarm raised	V
F3-10	T-REF when alarm raised	V
F3-11	Alarm/warn code 2 when alarm raised	
F3-12	Alarm/warn code 3 when alarm raised	
F3-13	Alarm/warn code 4 when alarm raised	
F3-14	Alarm/warn code 5 when alarm raised	
F3-15	Alarm/warn code 6 when alarm raised	
F3-16	Alarm/warn code 7 when alarm raised	

※1: F3-00=0 indicates that there is no alarm.

※2: F3-01=0 indicates that there is no warn.

5-4-5. Reset Parameters To Default

The following steps show how to reset parameters to default.

1. Press STATUS/ESC key to select Auxiliary Function.
2. Press INC or DEC key to set group No. to 3, and press ENTER key.
3. Press and hold ENTER key, and the panel displays “0” and is blinking.
4. Set the value to 1. Press and hold ENTER key to confirm.
5. Restart the driver and the parameters are all reset to default.

5-4-6. External Communication

Select F5-00 to run External communication function in auxiliary function, and the panel displays “c-out” meaning the driver is ready to be controlled by host controller, and COM1 is selected communicating with host controller. At this time the panel is disabled and host controller (mostly a PC) is used to debugging the servo driver. Press STATUS/ESC key to return and panel recovers from “c-out” to monitoring.

5-5. Parameter Setting

The following steps show how to change a parameter.

The parameter settings can be used to change parameter data. Check the permitted range of the parameters in 4-1 before changing the data.

The example below shows how to change parameter P3-09 from 2000 to 3000.

1. Press the STATUS/ESC key to select the parameter setting mode.

A digital panel display showing 'P0-00'. The first digit '0' is blinking.

2. At this time the second LED is blinking, and press INC or DEC key to set the group No. to 3. Press ENTER key to confirm.

A digital panel display showing 'P3-00'. The second digit '3' is blinking.

3. At this time the last LED is blinking, and press INC or DEC key to set the member No. to 9. Press and hold ENTER key to confirm.

A digital panel display showing 'P3-09'. The last digit '9' is blinking.

4. At this time the panel displays the value in P3-09, and the last decimal "0" is blinking. Press ENTER to left shift the blinking decimal. Press INC, DEC or ENTER key to modify the value to 3000, and press and hold ENTER to confirm.

A digital panel display showing '3200'. The first digit '3' is blinking.

The parameter in P3-09 is changed from 2000 to 3000.

Repeat steps 2 to 4 to change the setting again.

5. Press STATUS/ESC key to return and change group No. or member No..

5-6. Alarm

Alarm mode is switched automatically when an alarm is raised in servo driver, and an alarm code is displayed in form of "E-XXX". If there is no alarm in servo driver, the alarm mode is not available to display. If there is one or more alarms, press ENTER key to reset the alarm. The servo alarm will be reset if power supply is turned OFF

Note: If an alarm is ON, reset the alarm after eliminating the cause of the alarm first.

6 Ratings and Characteristics

This chapter provides the ratings, torque-speed characteristics diagrams, and dimensional drawings of the DS2 series servo drives and MS series servomotors.

6-1. Servomotors

This section describes ratings, specifications, and dimensional drawings of the servomotors. Refer to this section for selecting an appropriate servo drive.

6-1-1. Servomotor Ratings and Specifications

Voltage	220V			
Model MS-	60ST-M01330□□-20P4	80ST-M02430□□-20P7	110ST-M06030□□-21P5	130ST-M10015□□-21P5
Motor Code	0004	0011	0034	0044
Rated Capacity (kW)	0.4	0.75	1.5	1.5
Rated Current (A)	2.5	3.0	6.0	6.0
Rated Speed (rpm)	3000	3000	3000	1500
Rated Torque (N·m)	1.27	2.39	6	10
Peak Torque (N·m)	3.8	7.1	18	25
CEMF Contant (V/krpm)	28	48	61	103
Torque Constant (N·m/A)	0.5	0.8	1.0	1.67
Moment of Inertia (Kg·m ²)	0.30×10 ⁻⁴	0.24×10 ⁻³	0.76×10 ⁻³	1.94×10 ⁻³
Winding Resistance (Ω)	3.49	2.88	0.776	1.34
Winding Inductance (mH)	8.47	6.4	2.68	5.07
Inductive Time Constant (ms)	2.4	2.22	3.45	3.78
Weight (Kg)	1.33	2.86	6.7	11.5
Encoder Line (PPR)	2500			
Pole Pairs	4			
Insulation Class	Class B(130°C)		Class F(155°C)	
Enclosure	IP64		IP65	
Ambient	Temperature	0°C~40°C		-20°C~+50°C
	Humidity	Relative Humidity (r.h.) <90% with no condensation.		

■ 60 and 80 Series Servomotors Winding Connector

Motor Winding	Winding Name	U	V	W	PE
	Number	1	3	2	4

■ 60 and 80 Series Servomotors Encoder Connector

Name	5V	0V	B+	Z-	U+	Z+	U-	A+	V+	W+	V-	A-	B-	W-	PE
Number	2	3	4	5	6	7	8	9	10	11	12	13	14	15	1

■ 110 and 130 Series Servomotors Winding Connector

Motor Winding	Winding Name	U	V	W	PE
	Number	2	3	4	1

■ 110 and 130 Series Servomotors Encoder Connector

Name	5V	0V	A+	B+	Z+	A-	B-	Z-	U+	V+	W+	U-	V-	W-	PE
Number	2	3	4	5	6	7	8	9	10	11	12	13	14	15	1

6-1-2. Torque-Speed Feature

MS-60ST-M01330□□-20P4

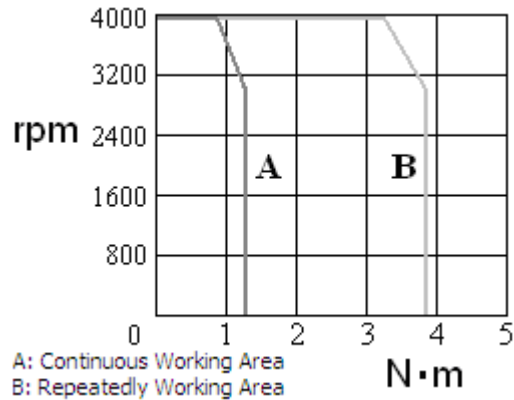

MS-80ST-M02430□□-20P7

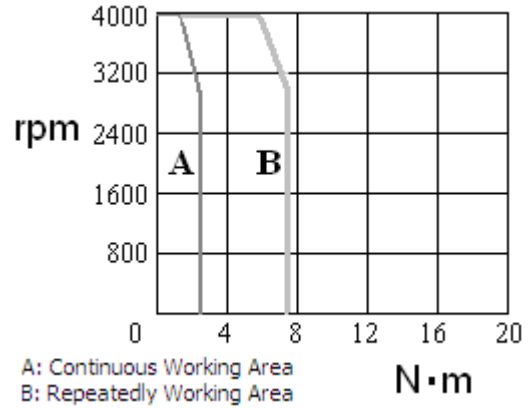

MS-110ST-M06030□□-21P5

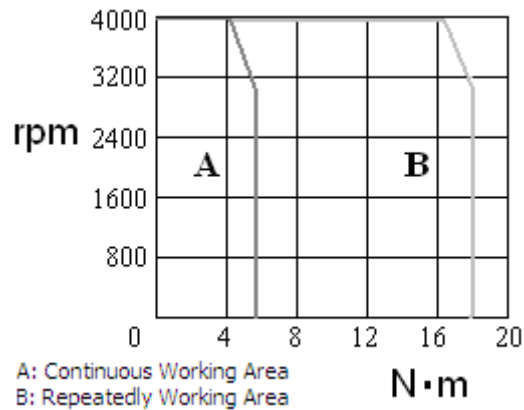

MS-130ST-M10015□□-21P5

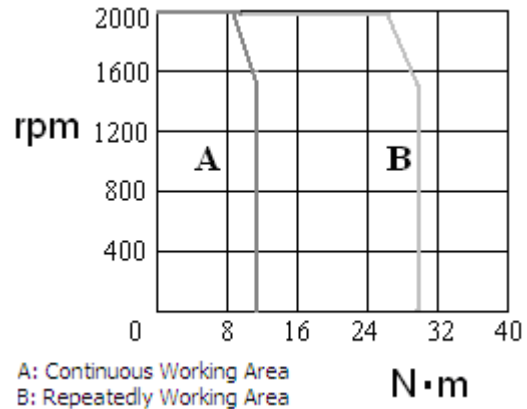

6-1-3. Servomotors Dimensions

■ Dimensions of 60 Series Servomotors (Unit: mm)

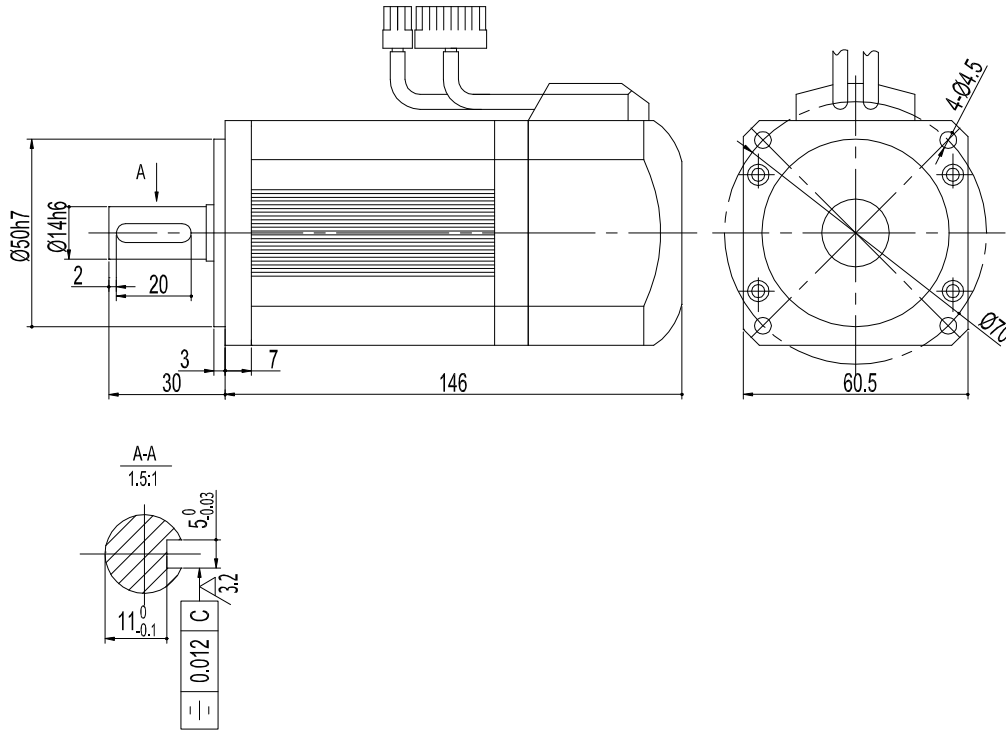

■ Dimensions of 60 Series Servomotors with Brake (Unit: mm)

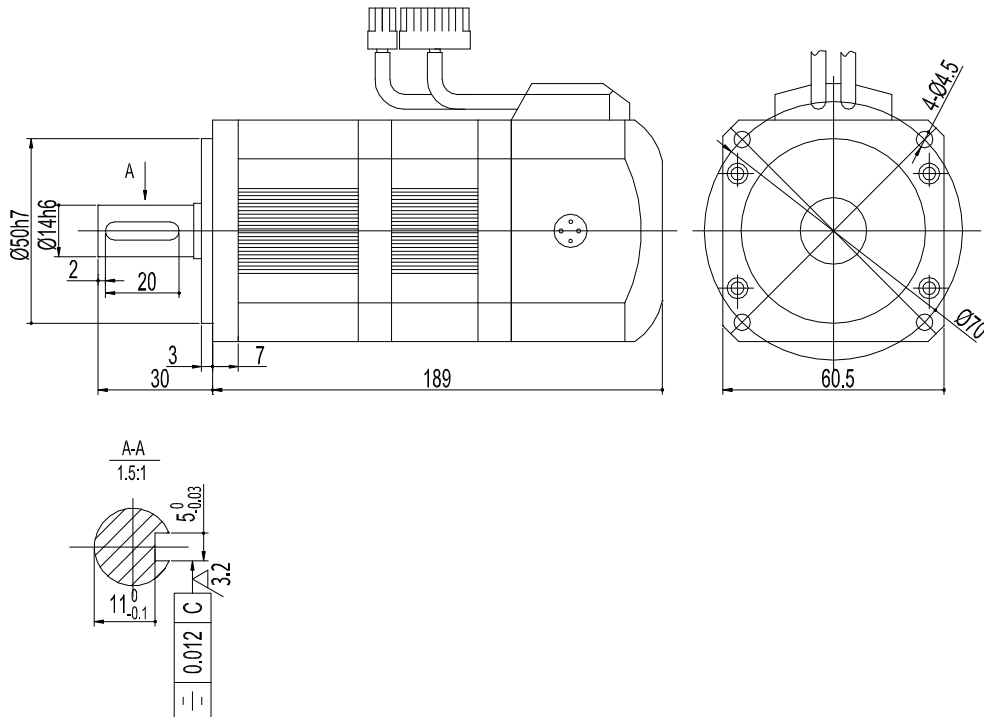

■ Dimensions of 80 Series Servomotors (Unit: mm)

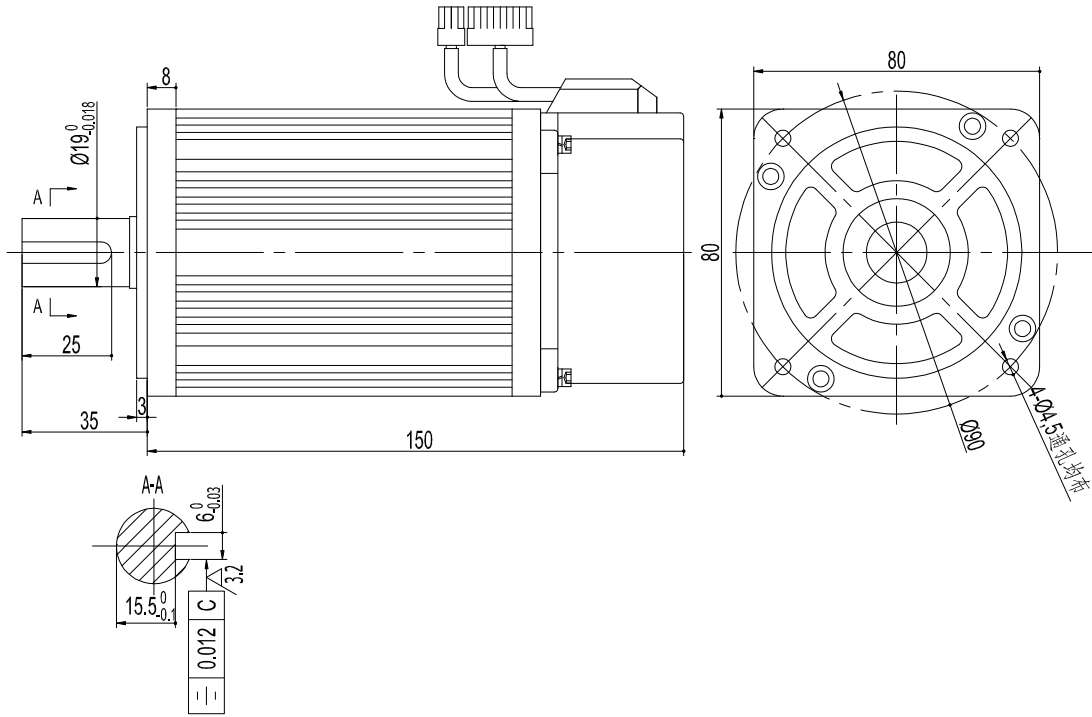

■ Dimensions of 80 Series Servomotors with Brake (Unit: mm)

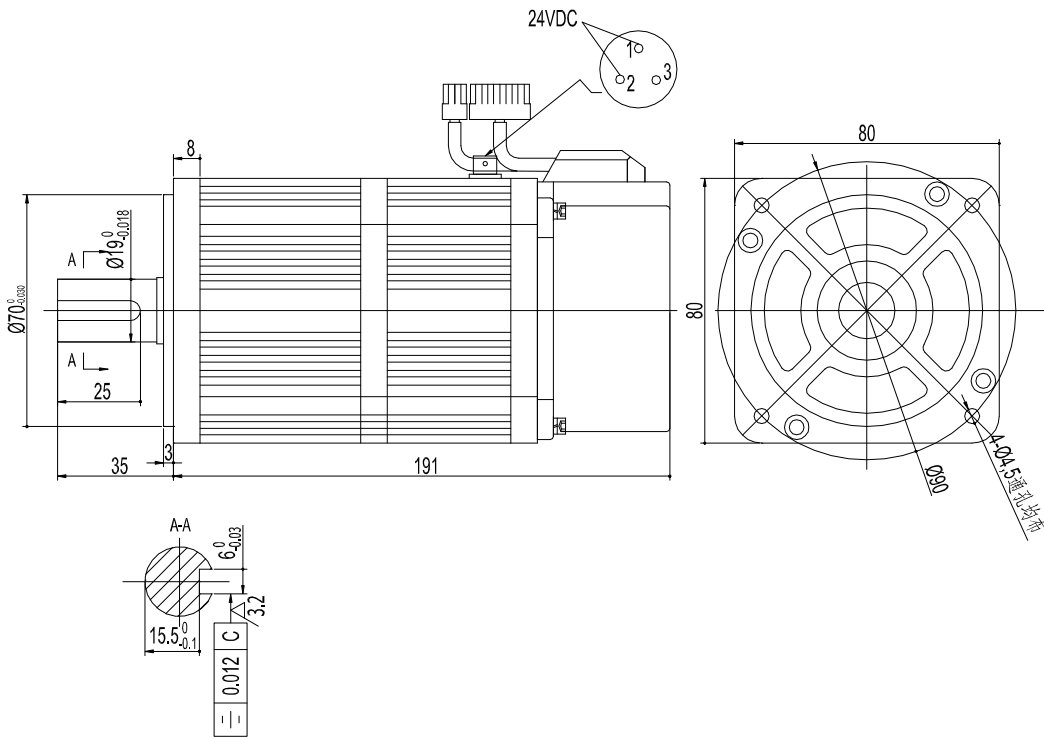

■ Dimensions of 110 Series Servomotors (Unit: mm)

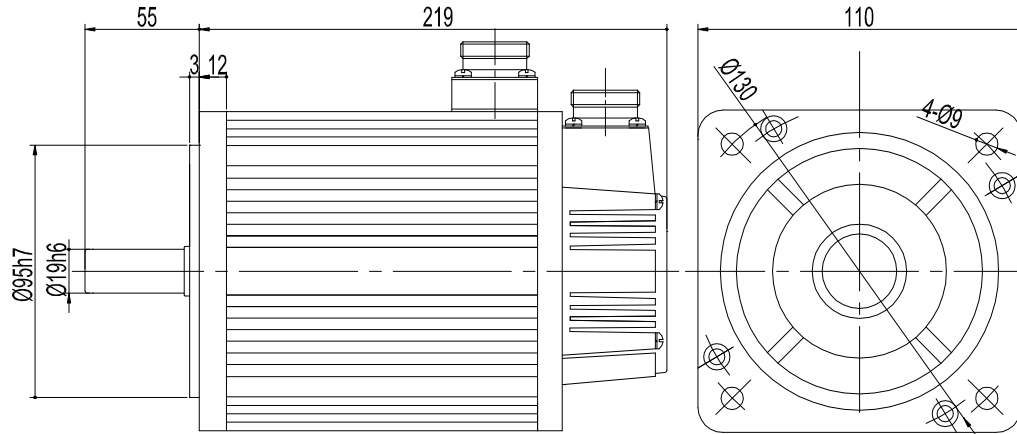

■ **Dimensions of 110 Series Servomotors with Brake (Unit: mm)**

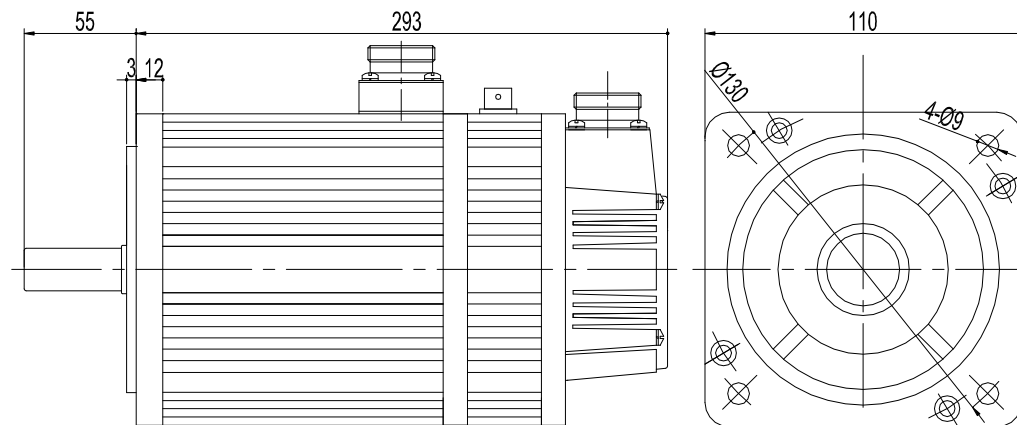

■ **Dimensions of 130 Series Servomotors (Unit: mm)**

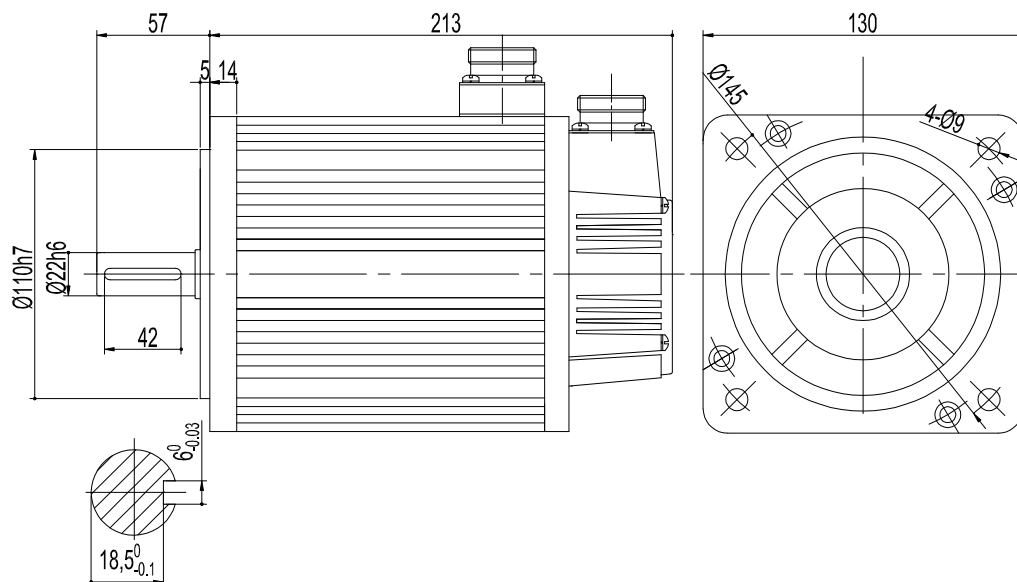

■ **Dimensions of 130 Series Servomotors with Brake (Unit: mm)**

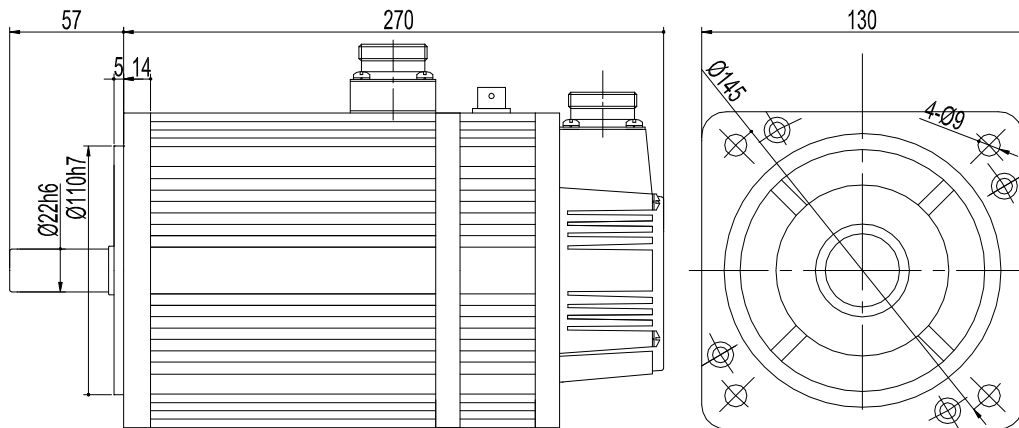

6-2. Servo Drivers

This section describes ratings, specifications, and dimensional drawings of the servo drivers.

6-2-1. Ratings

Servo Driver Model		DS2-20P4	DS2-20P7	DS2-21P5
Motor	Model	MS-60ST-M01330□□-20P4	MS-80ST-M02430□□-20P7	MS-110ST-M06030□□-21P5 MS-130ST-M10015□□-21P5
	Speed(rpm)	Rated 3000/Max 4000		Rated 1500/ Max 2000
Encoder		Standard: 2500 lines incremental decoder		
Max Motor Capacitor[kW]		0.4	0.75	1.5
Continuous Output Current [A rms]		2.5	3	6
Maximum Output Current [A rms]		7.5	9	18
Power Supply		Single Phase AC200~240V, 50/60Hz		
Control		Single phase full-wave rectification IPM-PWM (sinewave driven)		
Conditions	Ambient /Storage Temperature	0~+50 °C/-20~+85 °C		
	Ambient / Storage Humidity	Below 90%RH(with no condensation)		
	Vibration/Shock Resistance	4.9m/s ² / 19.6m/s ²		
Configuration		Base mounted		

6-2-2. Specifications

Servo Driver Model		DS2-20P4	DS2-20P7	DS2-21P5
Speed and Torque Control Modes	Performance	Speed Control Range		
		Speed Regulation	Load Regulation	1:4000(The lowest speed of the speed control range is the point just before the motor stops under full-load condition.)
			Voltage Regulation	0~100% load: 0.01% maximum (at rated speed)
			Temperature Regulation	Rated Voltage ±10%: 0% (at rated speed)
Frequency Characteristics		25 ± 25°C: ±0.1% max.(at rated speed)		
		250Hz (JL≤JM)		

		Soft Start Time Setting	0~65535ms(Can be set individually for acceleration and deceleration)		
	Input Reference		RS485		
Position Control Modes	Performance	Feedforward	0~100% (setting resolution: 1%)		
		Positioning Completed Width Setting	0~250 reference units (setting resolution: 1 reference unit)		
	Input Reference	Pulse Reference	Type	Sign + pulse, Quadrature Pulse	
			Form	Open collector(+24V level)	
			Frequency	200kbps	
Control Signal		Clear Signa (/CLR)			
Input / Output Signals	Position Output		None		
	Input Signal	Input Terminals	2	4	
		Signals Assignment	/S-ON、/P-CON、/P-OT、/N-OT、/ALM-RST、/PCL、/NCL、/SPD-D、/SPD-A、/SPD-B、/C-SEL、/ZCLAMP、/CLR、/G-SEL		
	Output Signal	Output Terminals	2	3	
		Signals Assignment	/COIN、/V-CMP、/TGON、/S-RDY、/CLT、/VLT、/BK、/WARN、/NEAR、/ALM、/Z		
Internal Functions	Dynamic Brake(DB)		None		
	Regeneration		External regenerative resistor		
	Overtravel Stop		Deceleration or free run to a stop at P-OT or N-OT		
	Electronic Gear		$0.01 \leq B/A \leq 100$		
	Protection		Program error, parameters error, overvoltage, undervoltage, overtemperature, overspeed, analog input error, position error overflow, output short circuit, current error, encoder loss, encoder error, overload, undervoltage in run, saving parameters error, etc.		
	LED Display		Charge, Power, five 7-segment LEDs (built-in digital operator functions)		
	Communications	COM1	Connected Devices	RS232, connected to PC	
			Parameters	Baudrate:19200, Data Bits:8, Stop Bits:1, Protocol:Modubs-RTU Slave, Modbus Station:1	
			Functions	Debug Online	
		COM2	Connected Devices	RS485, connected to PLC, HMI or other host controller and PC	
Parameters			Configurable, Protocol:Modubs-RTU Slave, Modbus Station: Configurable		
Functions			Status display, parameter setting, monitor display, alarm trace-back display, JOG and auto-tuning operations, speed, torque reference signal, and other drawing functions.		

6-2-3. Servo Drivers Dimensions

■ DS2-20P4 and DS2-20P7 (Unit: mm)

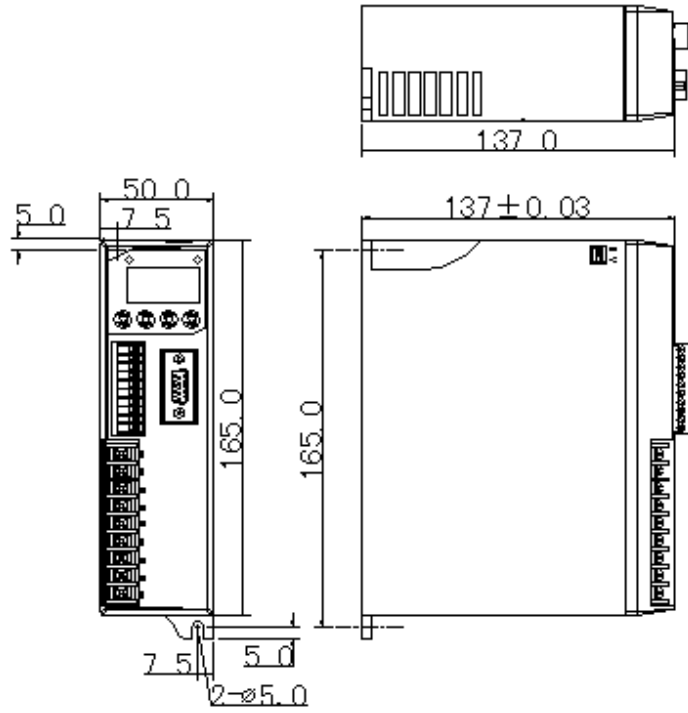

■ DS2-21P5 (Unit: mm)

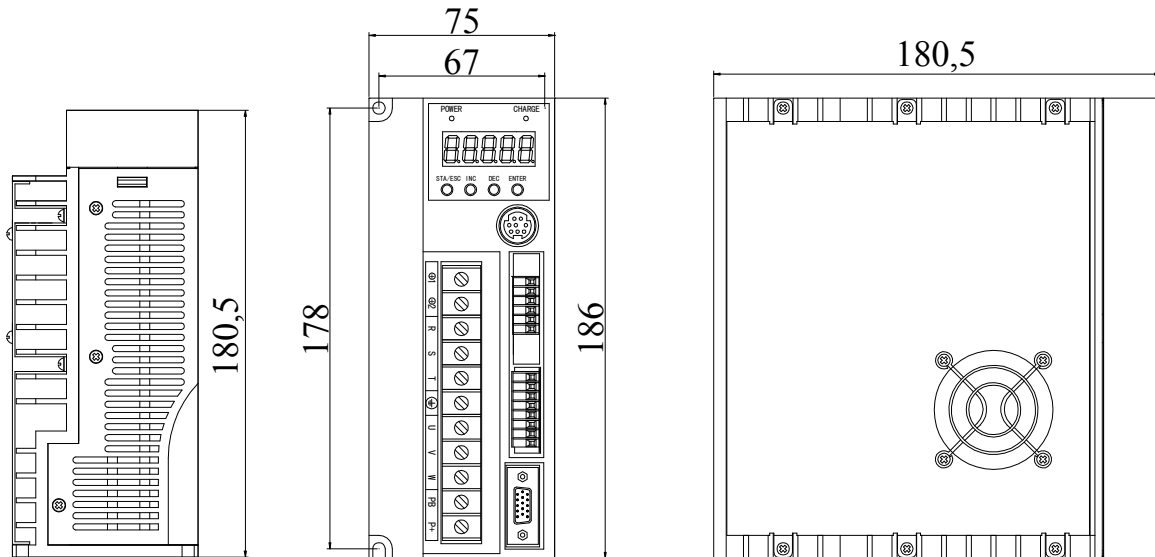

7 Alarm Information

This chapter describes the alarm information of DS2 series servo drivers.

Alarms

Alarm Code	Description	Causes	Solution
E-001	Program Damaged	Fail in program self-exam.	Re-download the program or contact Xinje or an authorized distributor
E-002	Parameter Damaged	Fail in parameter self-exam.	Restart the driver to reset the parameters to default. If it happens for many times contact Xinje or an authorized distributor
E-003	DC Over Voltage	Power grid is over voltage or need a regen resistor; the regen resistor is disconnected or the resistance is much higher.	Check the power grid; connect a regen resistor; check the regen resistor.
E-004	DC Under Voltage	Power grid is under voltage.	Check the power grid
E-005	Regen Resistor Error	Regen resistor is unavailable.	Check the regen resistor.
E-006	Module Over Temperature	Driver has been in high load for a long time; Ambient temperature is higher than normal.	Reduce the load, and enhance the cooling system, or check if the fan is revolving when motor is ON; cool down the ambient temperature.
E-007	Over Current	UVW of driver is short circuit or the motor is damaged.	Replace the damaged motor; check the UVW wiring.
E-008	Over Speed	Motor is revolving too fast, or the wiring of UVW of motor is not correct.	Check if there is other device that make motor revolve too fast; check the UVW wiring.
E-009	Analog Input Error	Analog input voltage exceeds error level.	Input appropriate voltage to analog input terminal.
E-010	Pulse Error Overflow	Error between reference pulse and actual pulse overflows the level.	Check if the motor is blocked to rotate; reduce the frequency of pulse reference; increase the overflow level P5-05.
E-011	Winding UVW Short Circuit	Circuit is shorted.	Check the UVW wiring of motor, or replace the damaged motor.
E-012	Winding UVW Current Error	Current convert circuit error.	Check the UVW wiring of motor, or replace the damaged driver.
E-013	Encoder UVW Loss	Encoder is loss, or the wiring is not correct, or the encoder is damaged.	Check the wiring of encoder, and re-connect the encoder after power-off, or replace the damaged encoder.

E-014	Encoder ABZ Loss	Encoder is loss, or the wiring is not correct, or the encoder is damaged.	Check the wiring of encoder, and re-connect the encoder after power-off, or replace the damaged encoder.
E-015	Speed Feedback Error	The wiring is not correct, or the encoder is interfered.	Check the wiring of encoder, or shield the encoder wire.
E-016	Overload	Overload time exceeds the level.	Reduce the time of overload, or replace with a bigger motor
E-017	Under Voltage when running	DC voltage is too low when running.	Restart the driver and wait for the DC to be balanced.
E-018	Erase Error	DC voltage is too low to erase the parameters.	Restart the driver.
E-031	Motor Code Error	The code indicated in F2-00 does not suitable for the driver.	Re-enter the motor code in F2-00.
E-032	Initialise Error	System chip is damaged.	Contact Xinje or an authorized distributor.

Note

